



SERVICE MANUAL

VHF MARINE TRANSCEIVER

IC-M15
IC-M15E

INTRODUCTION

This service manual describes the latest service information for the **IC-M15** VHF MARINE TRANSCEIVER at the time of publication.

3 versions of the IC-M15 have been designed. This service manual covers each version.

MODEL	VERSION NUMBER	VERSION	USABLE CHANNELS	SCAN	DUAL-WATCH	TRI-WATCH	VOICE SCRAMBLER (optional)
IC-M15	#01	USA	INT2 USA WX	●	●	●	●
IC-M15E	#02	EUR	INT1	—	●	—	—
IC-M15E	#03	UK	INT1 USA WX	●	●	●	●

●: Available

To upgrade quality, all electrical or mechanical parts and internal circuits are subject to change without notice or obligation.

DANGER

NEVER connect the transceiver to an AC outlet or to a DC power supply that uses more than 18 V. This will ruin the transceiver.

DO NOT expose the transceiver to rain, snow or any liquids.

DO NOT reverse the polarities of the power supply when connecting the transceiver.

DO NOT apply an RF signal of more than 20 dBm (100 mW) to the antenna connector. This could damage the transceiver's front end.

ORDERING PARTS

Be sure to include the following four points when ordering replacement parts:

1. 10-digit order numbers
2. Component part number and name
3. Equipment model name and unit name
4. Quantity required

<SAMPLE ORDER>

1150001240 IC SC-1223 IC-M15 MAIN UNIT 5 pieces
8810007990 Screw FH M2×4 SUS ZK IC-M15 Top panel 10 pieces

Addresses are provided on the inside back cover for your convenience.

REPAIR NOTES

1. Make sure a problem is internal before disassembling the transceiver.
2. **DO NOT** open the transceiver until the transceiver is disconnected from its power source.
3. **DO NOT** force any of the variable components. Turn them slowly and smoothly.
4. **DO NOT** short any circuits or electronic parts. An insulated tuning tool **MUST** be used for all adjustments.
5. **DO NOT** keep power ON for a long time when the transceiver is defective.
6. **DO NOT** transmit power into a signal generator or a sweep generator.
7. **ALWAYS** connect a 40 dB to 50 dB attenuator between the transceiver and a deviation meter or spectrum analyzer when using such test equipment.
8. **READ** the instructions of test equipment thoroughly before connecting equipment to the transceiver.

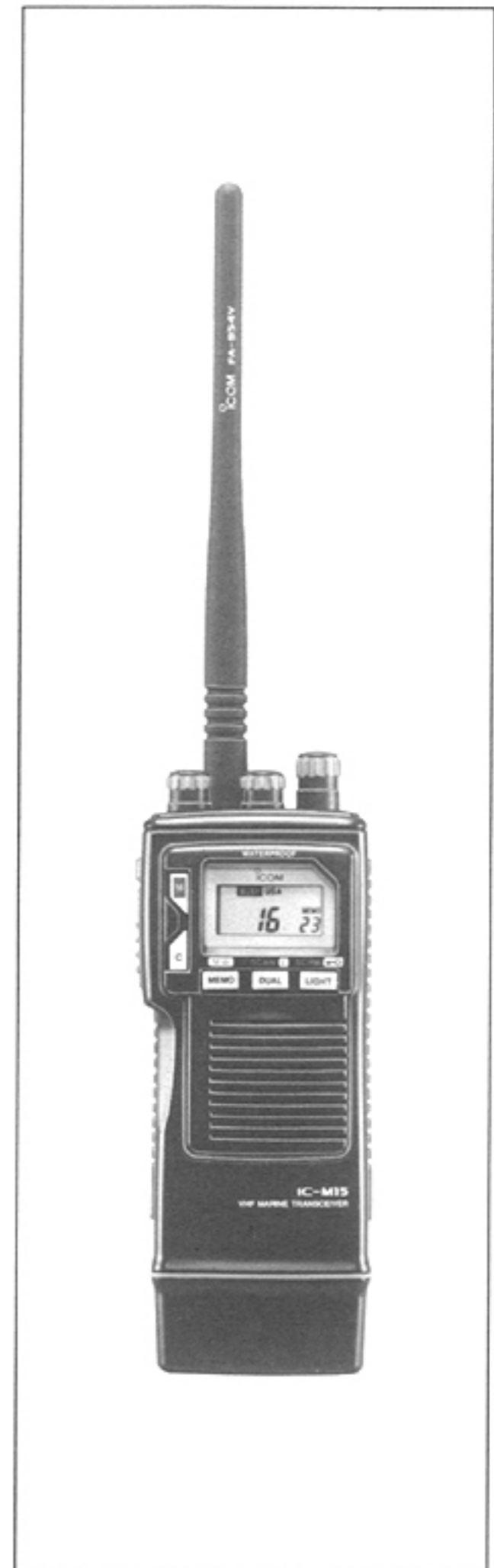

TABLE OF CONTENTS

SECTION 1	SPECIFICATIONS	1 - 1 to 2
SECTION 2	INSIDE VIEWS	2 - 1
SECTION 3	CIRCUIT DESCRIPTION	3 - 1 to 4
3 - 1	RECEIVER CIRCUITS	3 - 1
3 - 2	TRANSMITTER CIRCUITS	3 - 2
3 - 3	PLL CIRCUIT	3 - 3
3 - 4	POWER SUPPLY CIRCUITS	3 - 4
3 - 5	PORT ALLOCATIONS	3 - 4
SECTION 4	ADJUSTMENT PROCEDURES	4 - 1 to 2
4 - 1	PLL AND TRANSMITTER ADJUSTMENTS	4 - 1
4 - 2	RECEIVER ADJUSTMENT	4 - 2
SECTION 5	PARTS LIST	5 - 1 to 7
SECTION 6	MECHANICAL PARTS AND DISASSEMBLY	6 - 1 to 2
SECTION 7	BOARD LAYOUTS	7 - 1 to 7
7 - 1	PTT, VR, SENSOR, JACK AND SCRMN UNITS	7 - 1
7 - 2	LOGIC UNIT	7 - 2
7 - 3	MAIN UNIT	7 - 4
SECTION 8	OPTIONAL UNIT	8 - 1
SECTION 9	BLOCK DIAGRAM	9 - 1
SECTION 10	VOLTAGE DIAGRAM	10 - 1

SECTION 1 SPECIFICATIONS

■ GENERAL

- Frequency range : Transmit 156-157.5 MHz
Receive 156-163 MHz
- Mode : FM (16K0G3E)
- Channel spacing : 25 kHz
- Power supply requirement : CM-138 or CM-139
- Current drain (at 7.5 V DC) : Transmit High 3.0 A max.
Low 1.5 A max.
Receive Max. audio 600 mA max.
Squelched 15 mA typical
- Antenna impedance : 50 Ω (unbalanced)
- Usable temperature range : -20°C to $+60^{\circ}\text{C}$ (-4°F to $+140^{\circ}\text{F}$)
- Frequency stability : $\pm 0.0005\%$ (-20°C to $+60^{\circ}\text{C}$)
- Dimensions : 62(W) \times 150(H) \times 44(D) mm; 2.4(W) \times 5.9(H) \times 1.7(D) in
(with CM-138; projections not included)
- Weight : 460 g; 16.2 oz (with CM-138)

■ TRANSMITTER

- Output power : High 5 W
Low 700 mW
- Modulation system : Variable reactance phase modulation
- Microphone impedance : 2 k Ω
- Max. frequency deviation : ± 5 kHz
- Spurious emissions : -65 dB
- FM noise and hum : -40 dB
- Audio response : $+1$ dB to -3 dB of $+6$ dB/octave with 300 Hz to 3000 Hz input

■ RECEIVER

- Receive system : Double-conversion superheterodyne
- Sensitivity : 0.35 μV for 12 dB SINAD
- Intermediate frequencies : 1st 30.875 MHz
2nd 455 kHz
- Squelch sensitivity (at threshold) : Less than 0.3 μV
- Adjacent channel selectivity : -60 dB
- Intermodulation rejection : -60 dB (-68 dB for IC-M15E)
- Spurious rejection : -60 dB
- Audio output power : 500 mW with an 8 Ω load
- FM noise and hum : -40 dB
- Audio response : $+1$ dB to -3 dB of -6 dB/octave with 300 Hz to 3000 Hz modulation

All stated specifications are subject to change without notice or obligation.

■ VHF MARINE TRANSCEIVER CHANNEL CHART

Channel number			Frequency (MHz)		Channel number			Frequency (MHz)	
INT 1	INT 2	USA	Transmitter	Receiver	INT 1	INT 2	USA	Transmitter	Receiver
01	01		156.050	160.650	62	62		156.125	160.725
	01A	01A	156.050	156.050		62A	62A	156.125	156.125
02	02		156.100	160.700	63	63		156.175	160.775
	02A	02A	156.100	156.100		63A	63A	156.175	156.175
03	03		156.150	160.750	64	64		156.225	160.825
	03A	03A	156.150	156.150		64A	64A	156.225	156.225
04	04		156.200	160.800	65	65		156.275	160.875
	04A	04A	156.200	156.200		65A	65A	156.275	156.275
05	05		156.250	160.850	66	66		158.325	160.925
	05A	05A	156.250	156.250		66A	66A	156.325	156.325
06	06	06	156.300	156.300	67	67	67	156.375	156.375
07	07		156.350	160.950	68	68	68	156.425	156.425
	07A	07A	156.350	156.350	69	69	69	156.475	156.475
08	08	08	156.400	156.400	70	70	70	156.525	156.525
09	09	09	156.450	156.450	71	71	71	156.575	156.575
10	10	10	156.500	156.500	72	72	72	156.625	156.625
11	11	11	156.550	156.550	73	73	73	156.675	156.675
12	12	12	156.600	156.600	74	74	74	156.725	156.725
13	13	13	156.650	156.650	75	75	75	Guard	Guard
14	14	14	156.700	156.700	76	76	76	Guard	Guard
15	15	15*	156.750	156.750	77	77	77	156.875	156.875
16	16	16	156.800	156.800	78	78		156.925	161.525
17	17	17	156.850	156.850		78A	78A	156.925	156.925
18	18		156.900	161.500	79	79		156.975	161.575
	18A	18A	156.900	156.900		79A	79A	156.975	156.975
19	19		156.950	161.550	80	80		157.025	161.625
	19A	19A	156.950	156.950		80A	80A	157.025	157.025
20	20	20	157.000	161.600	81	81		157.075	161.675
	20A	20A	157.000	157.000		81A	81A	157.075	157.075
21	21		157.050	161.650	82	82		157.125	161.725
	21A	21A	157.050	157.050		82A	82A	157.125	157.125
22	22		157.100	161.700	83	83		157.175	161.775
	22A	22A	157.100	157.100		83A	83A	157.175	157.175
23	23		157.150	161.750	84	84	84	157.225	161.825
	23A	23A	157.150	157.150		84A		157.225	157.225
24	24	24	157.200	161.800	85	85	85	157.275	161.875
25	25	25	157.250	161.850		85A		157.275	157.275
26	26	26	157.300	161.900	86	86	86	157.325	161.925
27	27	27	157.350	161.950		86A	86A	157.325	157.325
28	28	28	157.400	162.000	87	87	87	157.375	161.975
60	60		156.025	160.625		87A		157.375	157.375
	60A	60A	156.025	156.025	88	88	88	157.425	162.025
61	61		156.075	160.675		88A	88A	157.425	157.425
	61A	61A	156.075	156.075					

WX channel	Frequency (MHz)		WX channel	Frequency (MHz)	
	Transmitter	Receiver		Transmitter	Receiver
WX 01	RX only	162.550	WX 06	RX only	162.500
WX 02	RX only	162.400	WX 07	RX only	162.525
WX 03	RX only	162.475	WX 08	RX only	161.650
WX 04	RX only	162.425	WX 09	RX only	161.775
WX 05	RX only	162.450	WX 10	RX only	163.275

* U.S.A. channel 15 is a receive-only channel.

SECTION 2 INSIDE VIEWS

• MAIN UNIT

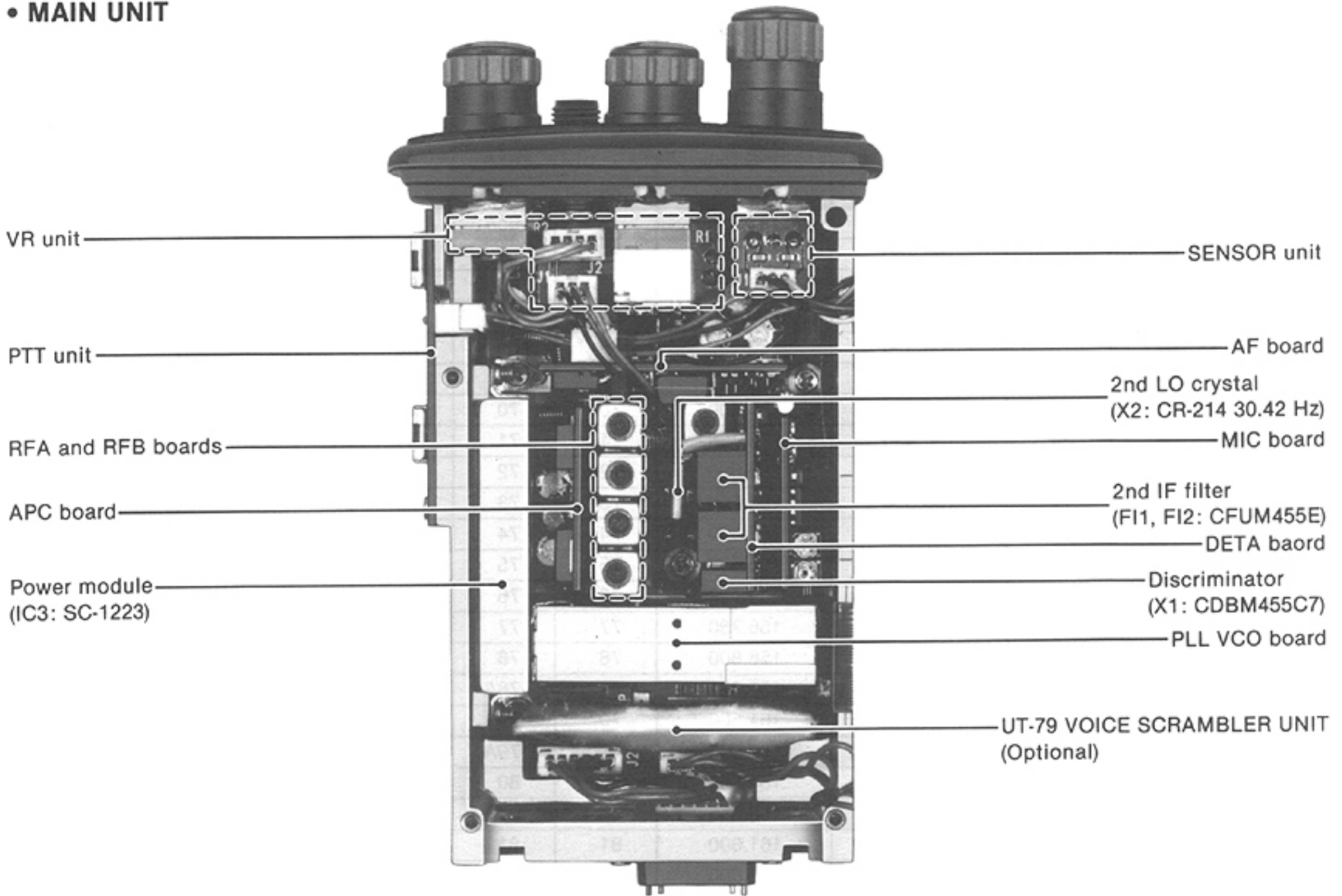

• LOGIC UNIT

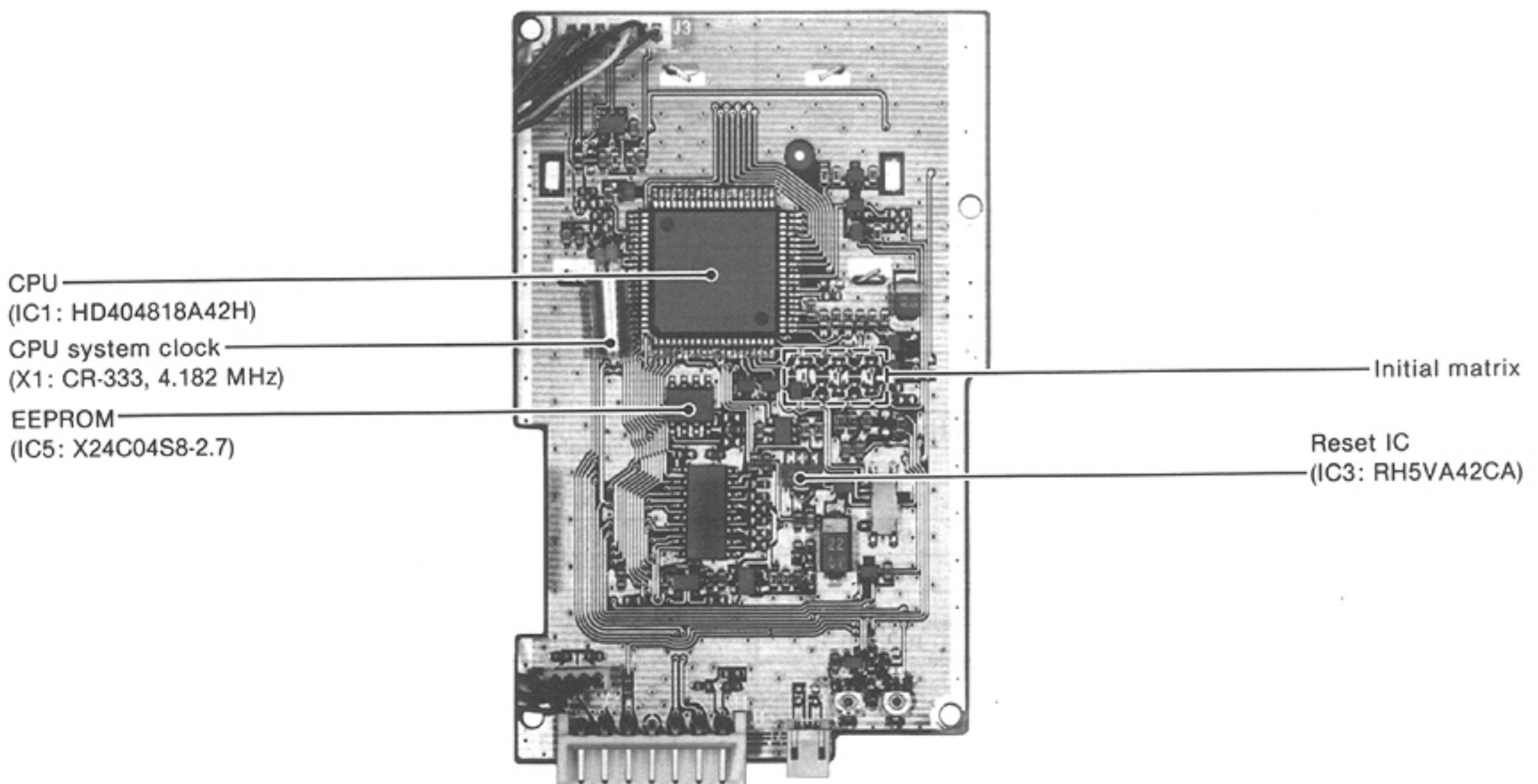

SECTION 3 CIRCUIT DESCRIPTION

3-1 RECEIVER CIRCUITS

3-1-1 ANTENNA SWITCHING CIRCUIT (MAIN UNIT)

The antenna switching circuit functions as a low-pass filter while receiving and a resonator circuit while transmitting. The circuit does not allow transmit signals to enter receiver circuits.

Received signals enter the antenna connector and then pass through the low-pass filter (L4, L5, C5, C6, C42–C44). The filtered signals are passed through the $\lambda/4$ type antenna switching circuit (D4, L1, L2, C38–C40) and are then applied to the RFA board.

3-1-2 RF AND 1ST MIXER CIRCUITS (RFA/RFB BOARDS AND MAIN UNIT)

The 1st mixer circuit converts the received signal to a fixed frequency of the 1st IF signal with a PLL output frequency. By changing the PLL frequency, only the desired frequency will be passed through a pair of crystal filters at the next stage of the 1st mixer.

The signals from the antenna switching circuit are passed through the tunable bandpass filter (L1, L2, D1, D2) and amplified at the RF amplifier (Q1). The amplified signals are again passed through the tunable bandpass filter (L3, L4, D3, D4) and applied to the MAIN unit. The signals are then mixed at the double balanced mixer (Q12, Q13) with a 1st LO signal coming from the PLL circuit to produce a 30.875 MHz 1st IF signal. The 1st IF signal is passed through a pair of crystal filters (F11) and is then applied to the DETA board.

3-1-3 2ND IF AND DEMODULATOR CIRCUITS (DETA BOARD)

The 2nd mixer circuit converts the 1st IF signal to a 2nd IF signal. A double superheterodyne system (which converts receive signal twice) improves the image rejection ratio and obtains stable receiver gain.

The 1st IF signal from the MAIN unit is amplified at Q1 and applied to a 2nd mixer section of IC1 (pin 20). The signal is then mixed with a 2nd LO signal for conversion to a 455 kHz 2nd IF signal.

IC1 contains the 2nd mixer, local oscillator, limiter amplifier, quadrature detector and active filter. The local oscillator section generates 30.42 MHz using X2.

The 2nd IF signal from the 2nd mixer (IC1, pin 4) passes through ceramic filters (F11, F12) to remove unwanted heterodyned frequencies. It is then amplified at the limiter amplifier (IC1, pin 6) and applied to the quadrature detector (IC1, pins 9, 10 and X1) to demodulate the 2nd IF signal into AF signals. The AF signals (detector signals) are output from pin 11 and applied to the MAIN unit via the "DETO" line.

FM DETECTOR AND SQUELCH CIRCUITS

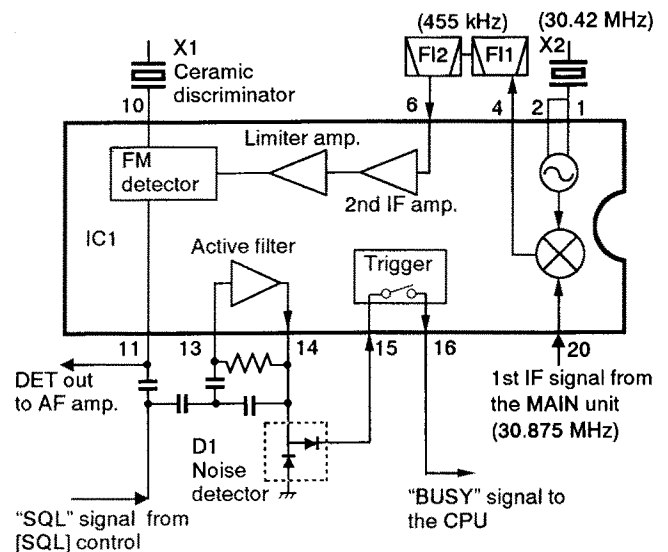

3-1-4 AF CIRCUIT (AF BOARD)

AF signals from the DETA board are passed through the SCRNM unit and are then applied to the AF board via the "DET" line. When an optional UT-79 is installed instead of the SCRNM unit, the scrambled audio is demodulated to a normal audio signal.

The signals are amplified at the active filters (Q4 HPF; Q5 LPF) and passed through the AF mute switch (Q6) and the [VOL] control (VR unit). The mute switch (Q6) cuts the audio line when the squelch closes.

The passed signals (via "AF2") are amplified at the AF power amplifier (IC1) to a level needed to drive the speaker.

For power conservation, the power supply circuit (Q1, Q2, Q3, D1) does not supply Vcc voltage to the AF power amplifier (IC1) when the squelch closes.

3-1-5 SQUELCH CIRCUIT (DETA and AF BOARDS)

A squelch circuit cuts out AF signals when no RF signal is received. By detecting noise components in the AF signals, the squelch circuit switches the AF mute switch in the AF board.

A portion of the AF signals from the FM IF IC (IC1, pin 11) are applied to the active filter (IC1, pin 13) where noise components above 20 kHz are amplified and output from pin 14. The [SQL] control is connected in parallel to the active filter input (pin 13) to control the input noise level. The output signals are rectified at the noise detector (D1) and then applied to the trigger circuit (pin 15).

The trigger circuit converts the rectified signals to a HIGH or LOW signal and applies this to the CPU (LOGIC unit IC1, pin 27) as the "BUSY" signal. When the CPU receives HIGH the CPU outputs the "RMUT" signal via the I/O expander IC (LOGIC unit IC4, pin 13) to cut the AF signals.

The "RMUT" signal is applied to the AF board and switches the AF mute switch (Q6). At the same time, the "AFON" signal disappears to deactivate the power supply circuit of the AF amplifier (Q1-Q3). However, it activates while emitting beeps.

3-2 TRANSMITTER CIRCUITS

3-2-1 MICROPHONE AMPLIFIER (MIC BOARD)

The microphone amplifier circuit amplifies audio signals with +6 dB/octave pre-emphasis characteristics from the microphone to a level needed for the modulation circuit.

The AF signals from the microphone are amplified at the limiter amplifier (MIC board IC1b) which has a negative feedback circuit for +6 dB/octave pre-emphasis.

The amplified signals pass through the SCRMN unit and are then returned to the MIC board. If an optional UT-79 is installed instead of the SCRMN unit, the audio signals are scrambled in there.

The returned signals are amplified at the buffer amplifier (IC2). RF components are then filtered out at the splatter filter (IC1a) and applied to the PLL VCO board as the "MOD" signal.

3-2-2 MODULATION CIRCUIT (PLL VCO BOARD)

The modulation circuit modulates the VCO oscillating signal (RF signal) using the microphone audio signals.

The audio signals (MOD) change the reactance of D3 on the PLL VCO board to modulate the oscillated signal at the transmitter VCO (Q7). The oscillated signal is amplified at the buffer amplifier (Q8, Q10), then applied to the drive amplifiers on the MAIN unit.

3-2-3 DRIVE/POWER AMPLIFIER CIRCUITS (MAIN UNIT)

The signal from the PLL VCO board is passed through the transmit/receive switching circuit (D5) and amplified by the driver (Q1), and the power module (IC3) in sequence to obtain 5 W of RF power. The amplified signal is passed through the APC detector circuit (L8, D2, D3, D9), antenna switching circuit (D1), and low-pass filter (L4, L5, C5, C6, C42-C44) and is then applied to the antenna connector.

The bias current of the power module (IC3) is controlled by the APC circuit to protect the power module from a mismatched condition as well as to stabilize the output power.

3-2-4 APC CIRCUIT (APC BOARD and MAIN UNIT)

The APC circuit protects the power module (MAIN unit IC3) from a mismatched output load and selects "High" or "Low" output power.

The APC detector circuit (MAIN unit L8, D2, D3, D9) detects forward signals and rectified signals at D2 and D3 on the MAIN unit respectively. The combined voltage is at a minimum level when the antenna is matched at 50 Ω and is increased when it is mismatched.

The detected voltage is applied to one of the differential amplifier inputs (Q3b) and a power setting voltage is applied to the other input (Q3a). When the antenna impedance is mismatched, the detected voltage exceeds the APC output current (Q1 collector) via Q2 to decrease the output power.

APC CIRCUIT

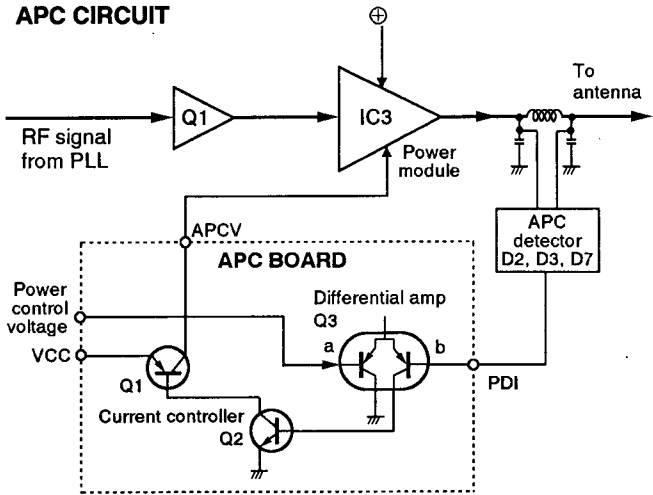

The IC-M15's PLL circuit contains a separate receiver VCO (Q6, D1) and transmitter VCO (Q7, D2). The oscillated signal is amplified at the buffer amplifier (Q8, Q9) and then applied to the PLL IC (IC1, pin 8)

The PLL IC (IC1) contains a prescaler, two programmable dividers, and a phase detector, etc. The entered signal is divided at the prescaler and programmable counter sections by the N-data ratio from the CPU. The divided signals are detected on phase at the phase detector using the reference frequency.

If the oscillated signal drifts, the phase of its frequency changes from the reference frequency, causing a lock voltage change to compensate for the drift in the oscillated frequency.

One of VCO signals is amplified at the buffer amplifiers (Q8, Q10) and is then applied to the receive 1st mixer or transmit driver circuit.

The lock voltage is also used for the receiver tunable bandpass filter to match the filter's center frequency to the desired receive frequency. The lock voltage is amplified at the buffer amplifier (MAIN unit Q5) and then applied to the RFA board.

3-3 PLL CIRCUIT (PLL VCO BOARD)

A PLL circuit provides stable oscillation of the transmitter frequency and the receive frequency. The PLL output frequency is controlled by the divided ratio (N-data) of the programmable divider.

PLL CIRCUIT BLOCK DIAGRAM

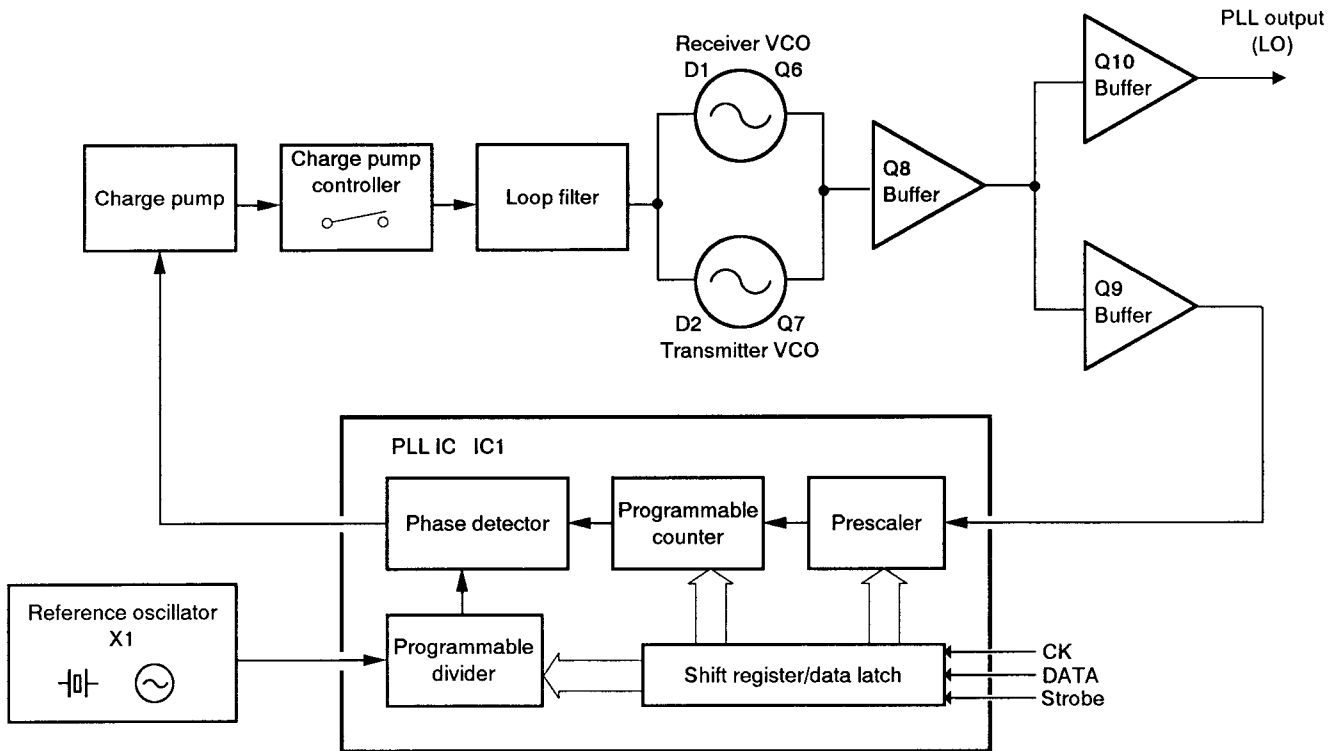

3-4 POWER SUPPLY CIRCUITS

VOLTAGE LINES (MAIN UNIT)

LINE	DESCRIPTION
H.V	The voltage from the attached battery pack.
VCC	The same voltage as the H.V line (battery voltage) which is controlled by the power switch ([OFF/VOL] control).
+5	Common 5 V converted from the VCC line by the 5 V regulator circuit (Q10, Q11, D8) using the reference regulator (IC4).
+5S	Common 5 V controlled by the power saver function. The "+5S" regulator circuit (Q6, Q7, D6, IC5) produces 5 V from the VCC voltage using the power save controlled signal from the I/O expander IC (LOGIC unit IC4).
R+5S	5 V for receiver circuit controlled by the power saver function and the T/R switching signal, "SEND" from the I/O expander IC (LOGIC unit IC4). The "R+5S" regulator consists of Q8, Q9, D7, IC6.
T+5	5 V for transmitter circuit controlled by the "TMUTE" signal from the I/O expander (LOGIC unit IC4). The "T+5" regulator circuit located on the APC board and consists of Q4, Q5 and D1.

3-5-2 CPU (LOGIC UNIT IC1)

PIN NO.	PORT NAME	DESCRIPTION
1	EXSTB	Outputs a strobe signal to the I/O expander IC (IC4).
2	EPDA	Used for the memory backup EPROM (IC5).
3	EPSC	
4	SCSTB	Outputs a strobe signal to an optional scrambler unit.
5	H/L CONT	Outputs a transmit high/low switching signal. "HIGH" for low power.
6	LAMPO	Outputs a display backlight signal. "HIGH" for backlight ON.
7	H/L KEY	Input port for the [HI/LOW] switch.
8	ENC /B	Input ports for the channel selector.
9	ENC B	
10	ENC A	
15-18	KS0-KS3	Output ports for the initial matrix and key matrix.
19-22	KI0-KI3	Input ports for the initial matrix and key matrix.
23	OPT IN	Input port for the optional scrambler unit connection.
27	BUSY	Input port for the noise squelch signal from the FM IF IC (DETA board IC1). "HIGH" when the squelch closes.
28	BEEP	Outputs beep tone signals.
29	INT0	Input port for the interrupt signal. "LOW" for CPU stand-by. "HIGH" for CPU operation.
30	PTT/CL IN	Input port for the [PTT] switch.
32-56	SEG2-SEG26	Output the LCD drive signal.
63	COM1	Output a common signal for the LCD display.
64	COM2	
74	OSC1	Terminals for CPU clock.
75	OSC2	
76	RESET	Input port for the CPU reset signal.
77	S.CK	Outputs clock signals to an optional scrambler unit.
78	UNLK	Input port for the PLL unlock signal.
79	S.DATA	Outputs serial data to an optional scrambler unit.
80	PLSTB	Outputs a strobe signal to the PLL IC (PLL VCO board IC1).

3-5 PORT ALLOCATIONS

3-5-1 EXPANDER IC (LOGIC UNIT IC4)

PIN No.	PORT NAME	DESCRIPTION
1	STB	Input port for a strobe signal from the CPU.
2	DATA	Input port for a data signal from the CPU.
3	CK	Input port for a clock signal from the CPU.
5	SC ON	Outputs a scrambler signal when an optional scrambler unit is in use.
6	PSC	Outputs a power save control signal to the MAIN unit.
7	CPC	Outputs a charge pump control signal to the PLL VCO board.
11	SEND	Outputs a transmit/receive switching signal. "HIGH" when transmitting.
12	TM	Outputs a transmit mute signal. "LOW" to mute the transmit power.
13	RMUTE	Outputs a receive mute signal. "HIGH" to mute the receive audio.
14	AF ON	Outputs an AF power amp control signal. "HIGH" to activate the AF amp.

SECTION 4 ADJUSTMENT PROCEDURES

4-1 PLL AND TRANSMITTER ADJUSTMENTS

ADJUSTMENT	ADJUSTMENT CONDITIONS	MEASUREMENT		VALUE	ADJUSTMENT POINT	
		UNIT	LOCATION		UNIT	ADJUST
PLL LOCK VOLTAGE	1 • Operating channel : 16 • Receiving	MAIN	Connect the digital multi-meter or oscilloscope to CP.	2.0 V	PLL VCO	L2
	2 • Transmitting			2.8 V		L5
PLL REFERENCE FREQUENCY	1 • Operating channel : 16 • Transmitting	MAIN	Loosely couple the frequency counter to the antenna connector.	156.800 MHz	PLL VCO	X1
OUTPUT POWER	1 • Operating channel : 16 • [HI/LOW] switch : HI • Transmitting	Top panel	Connect the RF power meter to the antenna connector.	5.0 W	LOGIC	R29
	2 • [HI/LOW] switch : LOW			0.7 W		R26
FM DEVIATION	1 • Operating channel : 16 • Apply an AF signal to J1 pins 4 and 5 (LOGIC UNIT): 1 kHz / 70 mV • Connect the FM deviation meter to the antenna connector and set as: HPF : OFF LPF : 20 kHz De-emphasis: OFF Detector : (P - P)/2 • Transmitting	Top panel	Connect the FM deviation meter to the antenna connector through the attenuator.	± 4.5 kHz	MIC	R19
	2 • Apply an AF signal to J1 pins 4 and 5 (LOGIC UNIT): 1 kHz / 7 mV			± 3.0 kHz		R20

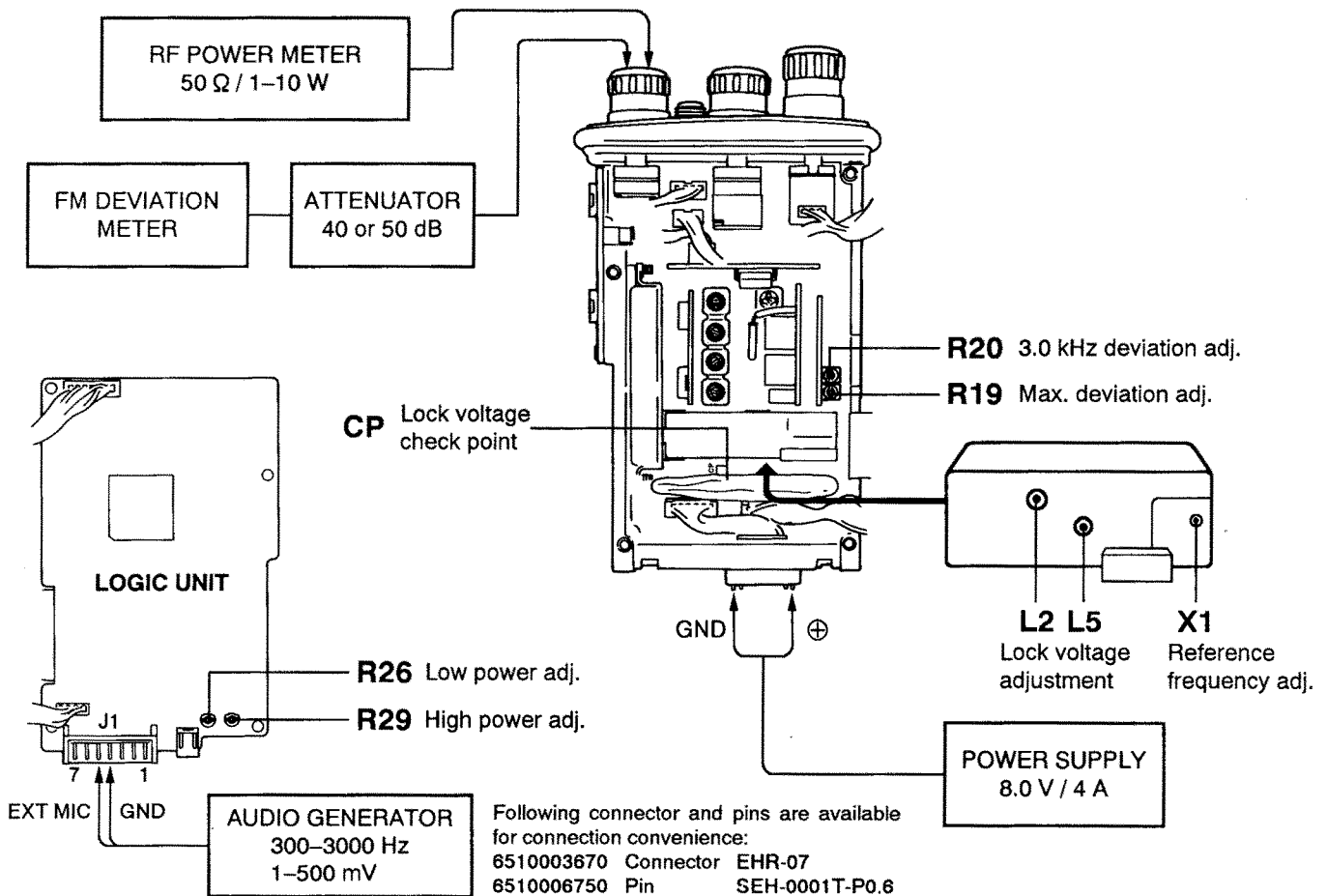

4-2 RECEIVER ADJUSTMENT

ADJUSTMENT	ADJUSTMENT CONDITIONS	MEASUREMENT		VALUE	ADJUSTMENT POINT	
		UNIT	LOCATION		UNIT	ADJUST
SENSITIVITY	1 <ul style="list-style-type: none"> Operating channel: 16 Connect the SSG to the antenna connector and set as: Frequency: 156.80 MHz Level : $3.2\mu\text{V}^*$ (-97 dBm) Deviation : ± 3.5 kHz Modulation: 1 kHz Receiving 			Preset cores of coils with the flat surface to the coil.	RFB	L1, L2 L3, L4
		DETA	Connect the oscilloscope to CP1.	Maximum level	RFB	Adjust in sequence: L1, L2 L3, L4
						MAIN

* This output level of the standard signal generator (SSG) is indicated as SSG's open circuit.

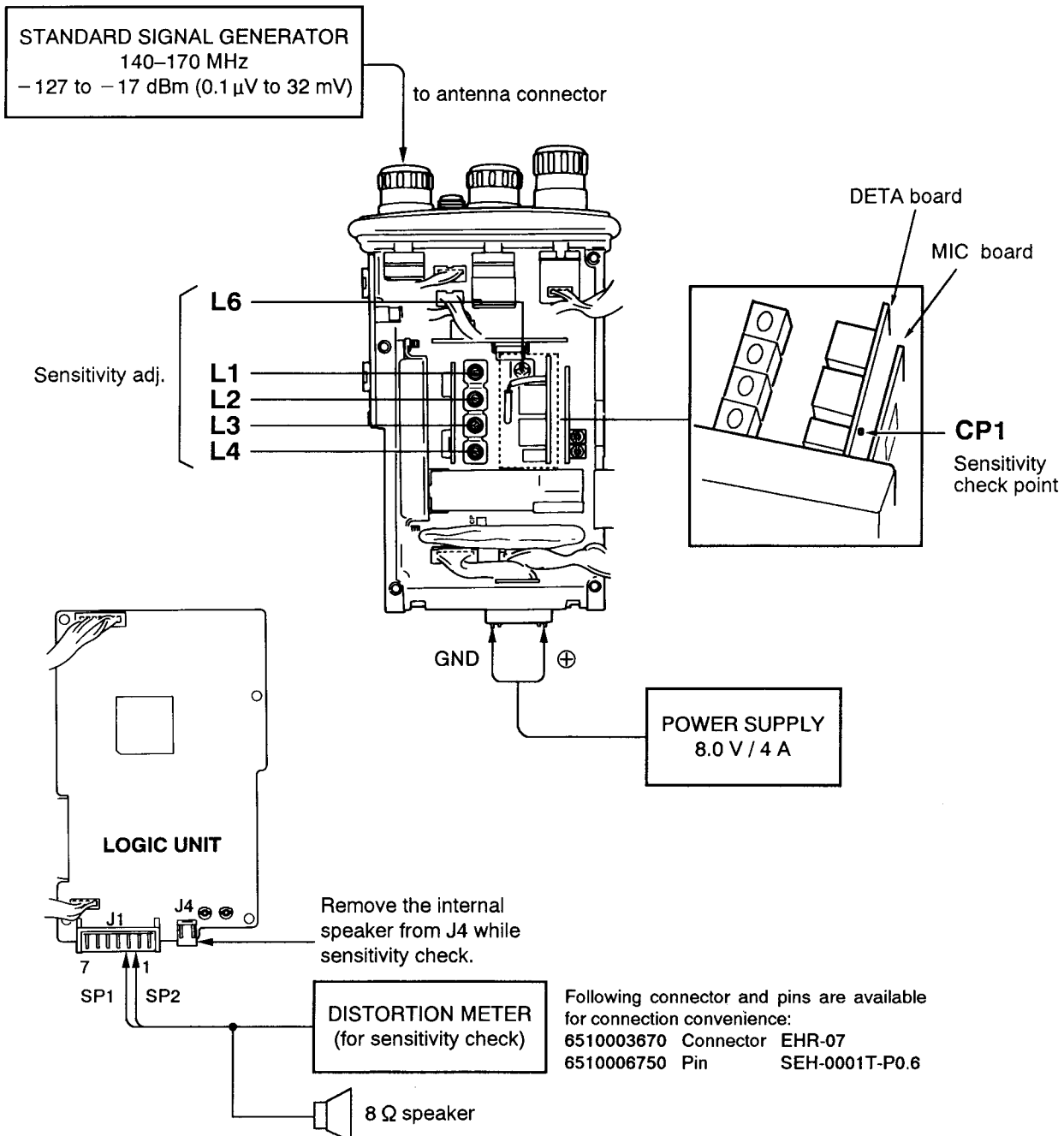

SECTION 5 PARTS LIST

[CHASSIS PARTS]

REF. NO.	ORDER NO.	DESCRIPTION	
J1	6510016530	CONNECTOR	SMA-R204 [ANT]
SP1	2510000700	SPEAKER	36D04BK-01

[MAIN UNIT]

REF. NO.	ORDER NO.	DESCRIPTION	
R5	7030003490	S. RESISTOR	ERJ3GEYJ 272 V (2.7 kΩ)
R6	7030003490	S. RESISTOR	ERJ3GEYJ 272 V (2.7 kΩ)
R7	7030003280	S. RESISTOR	ERJ3GEYJ 470 V (47 Ω)
R8	7030003460	S. RESISTOR	ERJ3GEYJ 152 V (1.5 kΩ)
R9	7030003560	S. RESISTOR	ERJ3GEYJ 103 V (10 kΩ)
R10	7030003320	S. RESISTOR	ERJ3GEYJ 101 V (100 kΩ)
R11	7030003680	S. RESISTOR	ERJ3GEYJ 104 V (100 kΩ)
R12	7030003520	S. RESISTOR	ERJ3GEYJ 472 V (4.7 kΩ)
R13	7030003520	S. RESISTOR	ERJ3GEYJ 472 V (4.7 kΩ)
R14	7030003560	S. RESISTOR	ERJ3GEYJ 103 V (10 kΩ)
R18	7030003520	S. RESISTOR	ERJ3GEYJ 472 V (4.7 kΩ)
R19	7030003560	S. RESISTOR	ERJ3GEYJ 103 V (10 kΩ)
R20	7030003720	S. RESISTOR	ERJ3GEYJ 224 V (220 kΩ)
R21	7030003680	S. RESISTOR	ERJ3GEYJ 104 V (100 kΩ)
R22	7030003520	S. RESISTOR	ERJ3GEYJ 472 V (4.7 kΩ)
R23	7030003520	S. RESISTOR	ERJ3GEYJ 472 V (4.7 kΩ)
R24	7030003270	S. RESISTOR	ERJ3GEYJ 390 V (39 Ω)
R25	7030003500	S. RESISTOR	ERJ3GEYJ 332 V (3.3 kΩ)
R26	7030003450	S. RESISTOR	ERJ3GEYJ 122 V (1.2 kΩ)
R27	7030003290	S. RESISTOR	ERJ3GEYJ 560 V (56 Ω)
R28	7030003280	S. RESISTOR	ERJ3GEYJ 470 V (47 Ω)
R29	7030003330	S. RESISTOR	ERJ3GEYJ 121 V (120 Ω)
R30	7030003520	S. RESISTOR	ERJ3GEYJ 472 V (4.7 kΩ)
R31	7030003370	S. RESISTOR	ERJ3GEYJ 271 V (270 Ω)
R32	7030003260	S. RESISTOR	ERJ3GEYJ 330 V (33 Ω)
R33	7030003340	S. RESISTOR	ERJ3GEYJ 151 V (150 Ω)
R34	7030003400	S. RESISTOR	ERJ3GEYJ 471 V (470 Ω)
R35	7030003560	S. RESISTOR	ERJ3GEYJ 103 V (10 kΩ)
R36	7030003560	S. RESISTOR	ERJ3GEYJ 103 V (10 kΩ)
R37	7030003560	S. RESISTOR	ERJ3GEYJ 103 V (10 kΩ)
R38	7030003400	S. RESISTOR	ERJ3GEYJ 471 V (470 Ω)
R39	7030003560	S. RESISTOR	ERJ3GEYJ 103 V (10 kΩ)
R40	7030003260	S. RESISTOR	ERJ3GEYJ 330 V (33 Ω)
R41	7030003380	S. RESISTOR	ERJ3GEYJ 331 V (330 Ω)
R42	7030003230	S. RESISTOR	ERJ3GEYJ 180 V (18 Ω)
R43	7030003370	S. RESISTOR	ERJ3GEYJ 271 V (270 Ω)
R44	7030003340	S. RESISTOR	ERJ3GEYJ 151 V (150 Ω)
R45	7030003380	S. RESISTOR	ERJ3GEYJ 331 V (330 Ω)
R46	7030003380	S. RESISTOR	ERJ3GEYJ 331 V (330 Ω)
R47	7030003340	S. RESISTOR	ERJ3GEYJ 151 V (150 Ω)
R48	7030003550	S. RESISTOR	ERJ3GEYJ 822 V (8.2 kΩ)
R49	7030003680	S. RESISTOR	ERJ3GEYJ 104 V (100 kΩ)
R50	7030003270	S. RESISTOR	ERJ3GEYJ 390 V (39 Ω)
R51	7030003620	S. RESISTOR	ERJ3GEYJ 333 V (33 kΩ)

[MAIN UNIT]

REF. NO.	ORDER NO.	DESCRIPTION	
IC1	1130006800	S. IC	TC7W08F (TE12L)
IC2	1130003610	S. IC	TC4SU69F (TE85R)
IC3	1150001240	IC	SC-1223
IC4	1180000800	S. IC	S-81350HG-KD-T1
IC5	1130004170	S. IC	TC4S01F (TE85R)
IC6	1130004170	S. IC	TC4S01F (TE85R)
Q1	1530002920	S. TRANSISTOR	2SC4226-T2 R25
Q2	1510000510	S. TRANSISTOR	2SA1576 T107 R
Q5	1560000540	S. FET	2SK880-Y (TE85R)
Q6	1530002280	S. TRANSISTOR	2SC4081 T107 S
Q7	1510000510	S. TRANSISTOR	2SA1576 T107 R
Q8	1530002280	S. TRANSISTOR	2SC4081 T107 S
Q9	1510000500	S. TRANSISTOR	2SA1162-GR (TE85R)
Q10	1530002280	S. TRANSISTOR	2SC4081 T107 S
Q11	1520000200	S. TRANSISTOR	2SB798-T2 DK
Q12	1530002920	S. TRANSISTOR	2SC4226-T2 R25
Q13	1530002920	S. TRANSISTOR	2SC4226-T2 R25
D1	1750000080	S. DIODE	1SS153-T2
D2	1790000980	S. DIODE	MA742 (TX)
D3	1790000980	S. DIODE	MA742 (TX)
D4	1790000450	S. DIODE	MA862 (TX)
D5	1790000450	S. DIODE	MA862 (TX)
D6	1790000590	S. DIODE	MA110 (TW)
D7	1790000590	S. DIODE	MA110 (TW)
D8	1160000060	S. DIODE	DAN202U T107
D9	1790000980	S. DIODE	MA742 (TX)
D10	1790001030	S. DIODE	SB30-03P-TD
FI1	2010001600	XTAL	FL-199 30.875MHZ
L1	6110002000	COIL	LA-226
L2	6110002070	COIL	LA-227
L3	6200000260	S. COIL	LQN 2A R10K
L4	6110002120	COIL	LA-228
L5	6110002070	COIL	LA-227
L6	6150003570	COIL	LS-393
L7	6200003380	S. COIL	B4F-617PT-1026=P3
L8	6110002070	COIL	LA-227
L9	6200000750	S. COIL	LQH 3N 4R7M
R1	7030003260	S. RESISTOR	ERJ3GEYJ 330 V (33 Ω)
R2	7030003380	S. RESISTOR	ERJ3GEYJ 331 V (330 Ω)

C1	4030006860	S. CERAMIC	C1608 JB 1H 102K-T-A
C2	4030006860	S. CERAMIC	C1608 JB 1H 102K-T-A
C3	4030006860	S. CERAMIC	C1608 JB 1H 102K-T-A
C4	4030006860	S. CERAMIC	C1608 JB 1H 102K-T-A
C5	4030006660	S. CERAMIC	C1608 SL 1H 220J-T-A
C6	4030006550	S. CERAMIC	C1608 SL 1H 040C-T-A
C7	4030006660	S. CERAMIC	C1608 SL 1H 220J-T-A
C8	4030006640	S. CERAMIC	C1608 SL 1H 180J-T-A
C9	4030006860	S. CERAMIC	C1608 JB 1H 102K-T-A
C10	4030008630	S. CERAMIC	C1608 JF 1C 104Z-T-A
C11	4510001380	ELECTROLYTIC	25 MS5 4R7 μF
C12	4030008630	S. CERAMIC	C1608 JF 1C 104Z-T-A
C13	4030006630	S. CERAMIC	C1608 SL 1H 150J-T-A
C14	4030006860	S. CERAMIC	C1608 JB 1H 102K-T-A
C15	4030006860	S. CERAMIC	C1608 JB 1H 102K-T-A
C16	4030006860	S. CERAMIC	C1608 JB 1H 102K-T-A
C17	4030006860	S. CERAMIC	C1608 JB 1H 102K-T-A
C18	4030006860	S. CERAMIC	C1608 JB 1H 102K-T-A
C19	4030006850	S. CERAMIC	C1608 JB 1H 471K-T-A
C20	4550000550	S. TANTALUM	TESVA 1V 224M1-8L
C21	4030006860	S. CERAMIC	C1608 JB 1H 102K-T-A
C22	4030006860	S. CERAMIC	C1608 JB 1H 102K-T-A
C23	4030006660	S. CERAMIC	C1608 SL 1H 220J-T-A
C24	4510003160	ELECTROLYTIC	16 RC2 22 μF (D=4.0)

S.=Surface mount

[MAIN UNIT]

REF. NO.	ORDER NO.	DESCRIPTION	
C25	4030008630	S. CERAMIC	C1608 JF 1C 104Z-T-A
C26	4510003160	ELECTROLYTIC	16 RC2 22 μ F (D=4.0)
C27	4030006850	S. CERAMIC	C1608 JB 1H 471K-T-A
C28	4030006850	S. CERAMIC	C1608 JB 1H 471K-T-A
C29	4030006850	S. CERAMIC	C1608 JB 1H 471K-T-A
C30	4510001520	ELECTROLYTIC	6.3 RC3 47 μ F
C31	4510003190	ELECTROLYTIC	6.3 RC2 47 μ F (D=4.0)
C32	4030006850	S. CERAMIC	C1608 JB 1H 471K-T-A
C33	4550002890	S. TANTALUM	TESVA 1A 225M1-8L
C34	4030006860	S. CERAMIC	C1608 JB 1H 102K-T-A
C35	4030006850	S. CERAMIC	C1608 JB 1H 471K-T-A
C36	4550002890	S. TANTALUM	TESVA 1A 225M1-8L
C37	4030006860	S. CERAMIC	C1608 JB 1H 102K-T-A
C38	4030006620	S. CERAMIC	C1608 SL 1H 120J-T-A
C39	4030006670	S. CERAMIC	C1608 SL 1H 270J-T-A
C40	4030006640	S. CERAMIC	C1608 SL 1H 180J-T-A
C41	4030009880	S. CERAMIC	C1608 JB 1H 682K-T-A
C42	4030006620	S. CERAMIC	C1608 SL 1H 120J-T-A
C43	4030006550	S. CERAMIC	C1608 SL 1H 040C-T-A
C44	4030006550	S. CERAMIC	C1608 SL 1H 040C-T-A
C45	4030006850	S. CERAMIC	C1608 JB 1H 471K-T-A
C46	4510003190	ELECTROLYTIC	6.3 RC2 47 μ F (D=4.0)
C47	4030006620	S. CERAMIC	C1608 SL 1H 120J-T-A
C48	4030006660	S. CERAMIC	C1608 SL 1H 220J-T-A
C49	4030006860	S. CERAMIC	C1608 JB 1H 102K-T-A
C50	4030006860	S. CERAMIC	C1608 JB 1H 102K-T-A
C51	4030006860	S. CERAMIC	C1608 JB 1H 102K-T-A
C52	4030009880	S. CERAMIC	C1608 JB 1H 682K-T-A
C53	4510003160	ELECTROLYTIC	16 RC2 22 μ F (D=4.0)
C54	4030006860	S. CERAMIC	C1608 JB 1H 102K-T-A
C55	4550002890	S. TANTALUM	TESVA 1A 225M1-8L
C56	4030008630	S. CERAMIC	C1608 JF 1C 104Z-T-A
C57	4030009880	S. CERAMIC	C1608 JB 1H 682K-T-A
C58	4030006860	S. CERAMIC	C1608 JB 1H 102K-T-A
C59	4550002890	S. TANTALUM	TESVA 1A 225M1-8L
C60	4030008630	S. CERAMIC	C1608 JF 1C 104Z-T-A
C61	4030008630	S. CERAMIC	C1608 JF 1C 104Z-T-A
J1	6510012880	S. CONNECTOR	CEW9114-0201
J2	6510009390	CONNECTOR	B6B-ZR
J3	6510009370	CONNECTOR	B4B-ZR
EP1	0910040903	PCB	B 3995C (MAIN)
EP2	0910041121	FPC	B 4132A

[RFA BOARD]

REF. NO.	ORDER NO.	DESCRIPTION	
R4	7030003700	S. RESISTOR	ERJ3GEYJ 154 V (150 k Ω)
R5	7030003700	S. RESISTOR	ERJ3GEYJ 154 V (150 k Ω)
R6	7030003320	S. RESISTOR	ERJ3GEYJ 101 V (100 Ω)
C1	4030006700	S. CERAMIC	C1608 SL 1H 390J-T-A
C2	4030006540	S. CERAMIC	C1608 SL 1H 030C-T-A
C3	4030008570	S. CERAMIC	C1608 SL 1H R75C-T-A
C4	4030006610	S. CERAMIC	C1608 SL 1H 100D-T-A
C5	4030006860	S. CERAMIC	C1608 JB 1H 102K-T-A
C6	4030006860	S. CERAMIC	C1608 JB 1H 102K-T-A
C7	4030006590	S. CERAMIC	C1608 SL 1H 080D-T-A
C8	4030006510	S. CERAMIC	C1608 SL 1H 0R5C-T-A
C9	4030006510	S. CERAMIC	C1608 SL 1H 0R5C-T-A
C10	4030006620	S. CERAMIC	C1608 SL 1H 120J-T-A
C11	4030006540	S. CERAMIC	C1608 SL 1H 030C-T-A
C12	4030006860	S. CERAMIC	C1608 JB 1H 102K-T-A
C14	4030006560	S. CERAMIC	C1608 SL 1H 050C-T-A
C15	4030006560	S. CERAMIC	C1608 SL 1H 050C-T-A
C16	4030006550	S. CERAMIC	C1608 SL 1H 040C-T-A
C17	4030006560	S. CERAMIC	C1608 SL 1H 050C-T-A
EP1	0910041100	PCB	B 4137 (RFA)
EP2	6910003110	LEADFRAME	HFB2.0-0.7-8 (N)

[RFB BOARD]

REF. NO.	ORDER NO.	DESCRIPTION	
L1	6150003580	COIL	LS-394
L2	6150003590	COIL	LS-395
L3	6150003600	COIL	LS-404
L4	6150003590	COIL	LS-395
EP1	0910024811	PCB	B 2384A (RFB)

[RFA BOARD]

REF. NO.	ORDER NO.	DESCRIPTION	
Q1	1560000550	S. FET	2SK882-Y (TE85R)
D1	1790000640	S. VARICAP	MA363B (TX)
D2	1790000640	S. VARICAP	MA363B (TX)
D3	1790000640	S. VARICAP	MA363B (TX)
D4	1790000640	S. VARICAP	MA363B (TX)
R1	7030003700	S. RESISTOR	ERJ3GEYJ 154 V (150 k Ω)
R2	7030003700	S. RESISTOR	ERJ3GEYJ 154 V (150 k Ω)
R3	7030003230	S. RESISTOR	ERJ3GEYJ 180 V (18 Ω)

[DETA BOARD]

REF. NO.	ORDER NO.	DESCRIPTION	
IC1	1120001650	S. IC	TK10487MTR
Q1	1530002020	S. TRANSISTOR	2SC3770-3-TA
D1	1790000490	S. DIODE	HSM88AS-TR
D2	1750000130	S. DIODE	DA204U T107

S.=Surface mount

[DETA BOARD]

REF. NO.	ORDER NO.	DESCRIPTION	
X1	6070000060	DISCRIMINATOR CDBM455C7	
X2	6050005010	XTAL CR-214	
F11	2020000550	CERAMIC	CFUM455E
F12	2020000550	CERAMIC	CFUM455E
R1	7030003480	S. RESISTOR	ERJ3GEYJ 222 V (2.2 kΩ)
R2	7030003440	S. RESISTOR	ERJ3GEYJ 102 V (1 kΩ)
R3	7030003520	S. RESISTOR	ERJ3GEYJ 472 V (4.7 kΩ)
R4	7030003460	S. RESISTOR	ERJ3GEYJ 152 V (1.5 kΩ)
R5	7030003400	S. RESISTOR	ERJ3GEYJ 471 V (4.7 kΩ)
R6	7030003730	S. RESISTOR	ERJ3GEYJ 274 V (270 kΩ)
R7	7030003730	S. RESISTOR	ERJ3GEYJ 274 V (270 kΩ)
R8	7030003480	S. RESISTOR	ERJ3GEYJ 222 V (2.2 kΩ)
R9	7030003520	S. RESISTOR	ERJ3GEYJ 472 V (4.7 kΩ)
R10	7030003680	S. RESISTOR	ERJ3GEYJ 104 V (100 kΩ)
R11	7030003480	S. RESISTOR	ERJ3GEYJ 222 V (2.2 kΩ)
R13	7030003400	S. RESISTOR	ERJ3GEYJ 471 V (4.7 kΩ)
R14	7030003400	S. RESISTOR	ERJ3GEYJ 471 V (4.7 kΩ)
R15	7030003670	S. RESISTOR	ERJ3GEYJ 823 V (82 kΩ)
R16	7030003430	S. RESISTOR	ERJ3GEYJ 821 V (820 Ω)
R17	7030003550	S. RESISTOR	ERJ3GEYJ 822 V (8.2 kΩ)
R18	7030003710	S. RESISTOR	ERJ3GEYJ 184 V (180 kΩ)
R19	7030003520	S. RESISTOR	ERJ3GEYJ 472 V (4.7 kΩ)
R20	7030003440	S. RESISTOR	ERJ3GEYJ 102 V (1 kΩ)
R21	7030003520	S. RESISTOR	ERJ3GEYJ 472 V (4.7 kΩ)
C1	4030008630	S. CERAMIC	C1608 JF 1C 104Z-T-A
C2	4030006740	S. CERAMIC	C1608 SL 1H 820J-T-A
C3	4030008630	S. CERAMIC	C1608 JF 1C 104Z-T-A
C4	4030008630	S. CERAMIC	C1608 JF 1C 104Z-T-A
C5	4030008630	S. CERAMIC	C1608 JF 1C 104Z-T-A
C6	4030006640	S. CERAMIC	C1608 SL 1H 180J-T-A
C7	4030006720	S. CERAMIC	C1608 SL 1H 560J-T-A
C8	4030006860	S. CERAMIC	C1608 JB 1H 102K-T-A
C9	4030006860	S. CERAMIC	C1608 JB 1H 102K-T-A
C10	4030006860	S. CERAMIC	C1608 JB 1H 102K-T-A
C11	4030006860	S. CERAMIC	C1608 JB 1H 102K-T-A
C12	4030006690	S. CERAMIC	C1608 SL 1H 330J-T-A
C13	4030008630	S. CERAMIC	C1608 JF 1C 104Z-T-A
C14	4030006850	S. CERAMIC	C1608 JB 1H 471K-T-A
C15	4030006860	S. CERAMIC	C1608 JB 1H 102K-T-A
C16	4550000550	S. TANTALUM	TESVA 1V 224M1-8L
C19	4030006860	S. CERAMIC	C1608 JB 1H 102K-T-A
C20	4030006900	S. CERAMIC	C1608 JB 1E 103K-T-A
C21	4030006850	S. CERAMIC	C1608 JB 1H 471K-T-A
C22	4030006900	S. CERAMIC	C1608 JB 1E 103K-T-A
C23	4030008630	S. CERAMIC	C1608 JF 1C 104Z-T-A
W1	7030003860	S. JUMPER	ERJ3GE JPW V
EP1	0910041080	PCB	B 4135 (DETA)
EP2	6910003110	LEADFRAME	HFB2.0-0.7-8 (N)

[AF BOARD]

REF. NO.	ORDER NO.	DESCRIPTION	
IC1	1110001510	IC	NJM2073D
Q1	1530002280	S. TRANSISTOR	2SC4081 T107 S
Q2	1530002280	S. TRANSISTOR	2SC4081 T107 S
Q3	1520000270	S. TRANSISTOR	2SB1182 TL Q
Q4	1530002280	S. TRANSISTOR	2SC4081 T107 S
Q5	1530002280	S. TRANSISTOR	2SC4081 T107 S
Q6	1590000520	S. FET	2SJ106-GR (TE85R)
D1	1750000260	S. DIODE	1SS352 (TPH3)
R1	7030003760	S. RESISTOR	ERJ3GEYJ 474 V (470 kΩ)
R2	7030003600	S. RESISTOR	ERJ3GEYJ 223 V (22 kΩ)
R3	7030003560	S. RESISTOR	ERJ3GEYJ 103 V (10 kΩ)
R4	7030003400	S. RESISTOR	ERJ3GEYJ 471 V (470 Ω)
R5	7030003360	S. RESISTOR	ERJ3GEYJ 221 V (220 Ω)
R6	7030003610	S. RESISTOR	ERJ3GEYJ 273 V (27 kΩ)
R7	7030003620	S. RESISTOR	ERJ3GEYJ 333 V (33 kΩ)
R8	7030003200	S. RESISTOR	ERJ3GEYJ 100 V (10 Ω)
R9	7030003710	S. RESISTOR	ERJ3GEYJ 184 V (180 kΩ)
R10	7030003630	S. RESISTOR	ERJ3GEYJ 273 V (27 kΩ)
R11	7030003480	S. RESISTOR	ERJ3GEYJ 222 V (2.2 kΩ)
R12	7030003760	S. RESISTOR	ERJ3GEYJ 474 V (470 kΩ)
R13	7030003560	S. RESISTOR	ERJ3GEYJ 103 V (10 kΩ)
R14	7030003610	S. RESISTOR	ERJ3GEYJ 273 V (27 kΩ)
R15	7030003610	S. RESISTOR	ERJ3GEYJ 273 V (27 kΩ)
R16	7030003480	S. RESISTOR	ERJ3GEYJ 222 V (2.2 kΩ)
R17	7030003480	S. RESISTOR	ERJ3GEYJ 222 V (2.2 kΩ)
R18	7030003800	S. RESISTOR	ERJ3GEYJ 105 V (1 M Ω)
R19	7030003720	S. RESISTOR	ERJ3GEYJ 224 V (220 kΩ)
R20	7030003200	S. RESISTOR	ERJ3GEYJ 100 V (10 Ω)
C1	4550000730	S. TANTALUM	TESVA 0J 225M1-8L
C2	4030006850	S. CERAMIC	C1608 JB 1H 471K-T-A
C3	4550006110	S. TANTALUM	TEMSVB2 0J 336M8L
C4	4030006860	S. CERAMIC	C1608 JB 1H 102K-T-A
C5	4030008630	S. CERAMIC	C1608 JF 1C 104Z-T-A
C6	4030008880	S. CERAMIC	C1608 JB 1C 223K-T-A
C7	4550006050	S. TANTALUM	TEMSVA 0J 106M8L
C8	4030008630	S. CERAMIC	C1608 JF 1C 104Z-T-A
C9	4030008900	S. CERAMIC	C1608 JB 1C 333K-T-A
C10	4030006900	S. CERAMIC	C1608 JB 1E 103K-T-A
C11	4030006900	S. CERAMIC	C1608 JB 1E 103K-T-A
C12	4030006850	S. CERAMIC	C1608 JB 1H 471K-T-A
C13	4030006860	S. CERAMIC	C1608 JB 1H 102K-T-A
C14	4550000460	S. TANTALUM	TESVA 1C 105M1-8L
C15	4030008630	S. CERAMIC	C1608 JF 1C 104Z-T-A
C16	4030008880	S. CERAMIC	C1608 JB 1C 223K-T-A
EP1	0910040893	PCB	B 3722C (AF)
EP2	6910003110	LEADFRAME	HFB2.0-0.7-8 (N)

S.=Surface mount

[MIC BOARD]

REF. NO.	ORDER NO.	DESCRIPTION	
IC1	1110002490	S. IC	M5218FP-73A
IC2	1110002750	S. IC	TA75S01F (TE85R)
Q1	1590001660	S. TRANSISTOR	XP4312 (TX)
R1	7030003670	S. RESISTOR	ERJ3GEYJ 823 V (82 kΩ)
R2	7030003670	S. RESISTOR	ERJ3GEYJ 823 V (82 kΩ)
R3	7030003700	S. RESISTOR	ERJ3GEYJ 154 V (150 kΩ)
R4	7030003410	S. RESISTOR	ERJ3GEYJ 561 V (560 Ω)
R5	7030003730	S. RESISTOR	ERJ3GEYJ 274 V (270 kΩ)
R6	7030003680	S. RESISTOR	ERJ3GEYJ 104 V (100 kΩ)
R7	7030003640	S. RESISTOR	ERJ3GEYJ 473 V (47 kΩ)
R8	7030003680	S. RESISTOR	ERJ3GEYJ 104 V (100 kΩ)
R9	7030003670	S. RESISTOR	ERJ3GEYJ 823 V (82 kΩ)
R10	7030003670	S. RESISTOR	ERJ3GEYJ 823 V (82 kΩ)
R11	7030003560	S. RESISTOR	ERJ3GEYJ 103 V (10 kΩ)
R12	7030003670	S. RESISTOR	ERJ3GEYJ 823 V (82 kΩ)
R13	7030003750	S. RESISTOR	ERJ3GEYJ 394 V (390 kΩ)
R14	7030003700	S. RESISTOR	ERJ3GEYJ 154 V (150 kΩ)
R15	7030003730	S. RESISTOR	ERJ3GEYJ 274 V (270 kΩ)
R16	7510000180	S. THERMISTOR	TN20-3S223LT
R17	7030003570	S. RESISTOR	ERJ3GEYJ 123 V (12 kΩ)
R18	7030003540	S. RESISTOR	ERJ3GEYJ 682 V (6.8 kΩ)
R19	7310003510	S. TRIMMER	RV-222 (RH03AVAS4) 473
R20	7310003920	S. TRIMMER	RV-227 (RH03AVAN5J) 334
R21	7030003520	S. RESISTOR	ERJ3GEYJ 472 V (4.7 kΩ)
C1	4030008860	S. CERAMIC	C1608 JB 1C 153K-T-A
C2	4030008860	S. CERAMIC	C1608 JB 1C 153K-T-A
C3	4030006860	S. CERAMIC	C1608 JB 1H 102K-T-A
C4	4030006880	S. CERAMIC	C1608 JB 1H 472K-T-A
C5	4030008650	S. CERAMIC	C1608 JB 1H 332K-T-A
C6	4550000530	S. TANTALUM	TESVA 1V 104M1-8L
C7	4030006850	S. CERAMIC	C1608 JB 1H 471K-T-A
C8	4510001470	ELECTROLYTIC	50 MS5 1 μF
C9	4030006850	S. CERAMIC	C1608 JB 1H 471K-T-A
C10	4030006860	S. CERAMIC	C1608 JB 1H 102K-T-A
C11	4030009490	S. CERAMIC	C1608 JB 1H 821K-T-A
C12	4030006850	S. CERAMIC	C1608 JB 1H 471K-T-A
C13	4030006740	S. CERAMIC	C1608 SL 1H 820J-T-A
C14	4030006860	S. CERAMIC	C1608 JB 1H 102K-T-A
EP1	0910040881	PCB	B 4057A (MIC)
EP2	6910003110	LEADFRAME	HFB2.0-0.7-8 (N)

[PLL VCO BOARD]

REF. NO.	ORDER NO.	DESCRIPTION	
Q7	1560000330	S. FET	2SK210-GR (TE85R)
Q8	1530002600	S. TRANSISTOR	2SC4215-O (TE85R)
Q9	1530002600	S. TRANSISTOR	2SC4215-O (TE85R)
Q10	1530002600	S. TRANSISTOR	2SC4215-O (TE85R)
D1	1790000640	S. VARICAP	MA363B (TX)
D2	1790000640	S. VARICAP	MA363B (TX)
D3	1790000640	S. VARICAP	MA363B (TX)
X1	6050008640	XTAL	CR-448 12.800MHZ
L1	6200000750	S. COIL	LQH 3N 4R7M
L2	6130002360	S. COIL	LB-257
L3	6200000750	S. COIL	LQH 3N 4R7M
L4	6200000750	S. COIL	LQH 3N 4R7M
L5	6130002370	S. COIL	LB-258
L6	6200000750	S. COIL	LQH 3N 4R7M
L7	6200000260	S. COIL	LQN 2A R10K
L8	6200000260	S. COIL	LQN 2A R10K
R1	7030003560	S. RESISTOR	ERJ3GEYJ 103 V (10 kΩ)
R2	7030003680	S. RESISTOR	ERJ3GEYJ 104 V (100 kΩ)
R3	7030003680	S. RESISTOR	ERJ3GEYJ 104 V (100 kΩ)
R4	7030003600	S. RESISTOR	ERJ3GEYJ 223 V (22 kΩ)
R5	7030003520	S. RESISTOR	ERJ3GEYJ 472 V (4.7 kΩ)
R6	7030003600	S. RESISTOR	ERJ3GEYJ 223 V (22 kΩ)
R7	7030003560	S. RESISTOR	ERJ3GEYJ 103 V (10 kΩ)
R8	7030003440	S. RESISTOR	ERJ3GEYJ 102 V (1 kΩ)
R9	7030003390	S. RESISTOR	ERJ3GEYJ 391 V (390 Ω)
R10	7030003550	S. RESISTOR	ERJ3GEYJ 822 V (8.2 kΩ)
R11	7030003310	S. RESISTOR	ERJ3GEYJ 820 V (82 Ω)
R12	7030003680	S. RESISTOR	ERJ3GEYJ 104 V (100 kΩ)
R13	7030003610	S. RESISTOR	ERJ3GEYJ 273 V (27 kΩ)
R14	7030003260	S. RESISTOR	ERJ3GEYJ 330 V (33 Ω)
R15	7030003660	S. RESISTOR	ERJ3GEYJ 683 V (68 kΩ)
R16	7030003420	S. RESISTOR	ERJ3GEYJ 681 V (680 Ω)
R17	7030003420	S. RESISTOR	ERJ3GEYJ 681 V (680 Ω)
R18	7030003660	S. RESISTOR	ERJ3GEYJ 683 V (68 kΩ)
R19	7030003650	S. RESISTOR	ERJ3GEYJ 563 V (56 kΩ)
R20	7030003390	S. RESISTOR	ERJ3GEYJ 391 V (390 Ω)
C1	4030008630	S. CERAMIC	C1608 JF 1C 104Z-T-A
C2	4030006860	S. CERAMIC	C1608 JB 1H 102K-T-A
C3	4030008630	S. CERAMIC	C1608 JF 1C 104Z-T-A
C4	4030008630	S. CERAMIC	C1608 JF 1C 104Z-T-A
C5	4030008630	S. CERAMIC	C1608 JF 1C 104Z-T-A
C6	4550003080	S. TANTALUM	TEMSVA 1A 335M-8L
C7	4030008630	S. CERAMIC	C1608 JF 1C 104Z-T-A (#01)
	4030008920	S. CERAMIC	C1608 JB 1C 473K-T-A (#02, #03)
C8	4030006670	S. CERAMIC	C1608 SL 1H 270J-T-A
C9	4030006570	S. CERAMIC	C1608 SL 1H 060D-T-A
C10	4030006550	S. CERAMIC	C1608 SL 1H 040C-T-A
C11	4030006860	S. CERAMIC	C1608 JB 1H 102K-T-A
C12	4030006510	S. CERAMIC	C1608 SL 1H 0R5C-T-A
C13	4030006510	S. CERAMIC	C1608 SL 1H 0R5C-T-A
C14	4030006750	S. CERAMIC	C1608 SL 1H 101J-T-A
C15	4030006520	S. CERAMIC	C1608 SL 1H 010C-T-A
C16	4550000460	S. TANTALUM	TESVA 1C 105M1-8L
C17	4030006550	S. CERAMIC	C1608 SL 1H 040C-T-A
C18	4030006540	S. CERAMIC	C1608 SL 1H 030C-T-A
C19	4030008630	S. CERAMIC	C1608 JF 1C 104Z-T-A
C20	4030006510	S. CERAMIC	C1608 SL 1H 0R5C-T-A
C21	4030006510	S. CERAMIC	C1608 SL 1H 0R5C-T-A
C22	4030006860	S. CERAMIC	C1608 JB 1H 102K-T-A
C23	4030006550	S. CERAMIC	C1608 SL 1H 040C-T-A
C24	4030006640	S. CERAMIC	C1608 SL 1H 180J-T-A
C25	4030006620	S. CERAMIC	C1608 SL 1H 120J-T-A
C26	4030006860	S. CERAMIC	C1608 JB 1H 102K-T-A

S.=Surface mount

[PLL VCO BOARD]

REF. NO.	ORDER NO.	DESCRIPTION	
IC1	1140001310	S. IC	MB1504PF-G-BND
IC2	1130004200	S. IC	TC4S66F (TE85R)
Q1	1590000440	S. TRANSISTOR	DTA143ZU T107
Q2	1590000430	S. TRANSISTOR	DTC144EU T107
Q3	1590000970	S. TRANSISTOR	FMA2 T148
Q4	1510000620	S. TRANSISTOR	2SA1576 T107 S
Q5	1530002280	S. TRANSISTOR	2SC4081 T107 S
Q6	1560000340	S. FET	2SK210-Y (TE85R)

[PLL VCO BOARD]

REF. NO.	ORDER NO.	DESCRIPTION	
C27	4030006620	S. CERAMIC	C1608 SL 1H 120J-T-A
C28	4030006860	S. CERAMIC	C1608 JB 1H 102K-T-A
J1	6510012250	CONNECTOR	TKX-P04P-A2
J2	6510012310	CONNECTOR	TKX-P10P-A2
W1	7030003860	S. JUMPER	ERJ3GE JPW V
EP1	0910039552	PCB	B 3844B (PLL VCO)

[LOGIC UNIT]

REF. NO.	ORDER NO.	DESCRIPTION	
IC1	1140003680	S. IC	HD4074818H (#01)
	1140004110	S. IC	HD404818A42H (#02, #03)
IC2	1130003760	S. IC	TC4S81F (TE85R)
IC3	1180000610	S. IC	RH5VA42CA-T1
IC4	1130005810	S. IC	BU4094BF-T1
IC5	1140003610	S. IC	X24C04S8-2.7
IC6	1130003610	S. IC	TC4SU69F (TE85R)
IC7	1110002750	S. IC	TA75S01F (TE85R)
IC8	1130003760	S. IC	TC4S81F (TE85R)
Q1	1590000430	S. TRANSISTOR	DTC144EU T107
Q2	1530002060	S. TRANSISTOR	2SC4081 T107 R
Q3	1590000430	S. TRANSISTOR	DTC144EU T107
Q4	1510000510	S. TRANSISTOR	2SA1576 T107 R
Q5	1590000430	S. TRANSISTOR	DTC144EU T107
D1	1750000160	S. DIODE	DA114 T107
D2	1750000130	S. DIODE	DA204U T107
D3	1750000240	S. DIODE	DA112 T107
D4	1750000170	S. DIODE	DA115 T107
D5	1750000170	S. DIODE	DA115 T107
D6	1160000050	S. DIODE	DAP202U T107 (#02)
	1750000240	S. DIODE	DA112 T107 (#03)
D7	1750000240	S. DIODE	DA112 T107 (#02, #03)
D8	1750000220	S. DIODE	DA113W T107 (#02, #03)
D9	1750000220	S. DIODE	DA113W T107 (#02)
D10	1750000220	S. DIODE	DA113W T107 (#01)
	1160000050	S. DIODE	DAP202U T107 (#02, #03)
D12	1750000240	S. DIODE	DA112 T107
X1	6050006980	XTAL	CR-333 AT-38 4.182MHZ
R1	7030003800	S. RESISTOR	ERJ3GEYJ 105 V (1 MΩ)
R2	7030003800	S. RESISTOR	ERJ3GEYJ 105 V (1 MΩ)
R3	7030003800	S. RESISTOR	ERJ3GEYJ 105 V (1 MΩ)
R4	7030003800	S. RESISTOR	ERJ3GEYJ 105 V (1 MΩ)
R5	7030003800	S. RESISTOR	ERJ3GEYJ 105 V (1 MΩ)
R6	7030003800	S. RESISTOR	ERJ3GEYJ 105 V (1 MΩ)
R7	7030003800	S. RESISTOR	ERJ3GEYJ 105 V (1 MΩ)
R8	7030003640	S. RESISTOR	ERJ3GEYJ 473 V (47 kΩ)
R9	7030003640	S. RESISTOR	ERJ3GEYJ 473 V (47 kΩ)
R10	7030003640	S. RESISTOR	ERJ3GEYJ 473 V (47 kΩ)
R11	7030003640	S. RESISTOR	ERJ3GEYJ 473 V (47 kΩ)
R12	7030003640	S. RESISTOR	ERJ3GEYJ 473 V (47 kΩ)
R13	7030003640	S. RESISTOR	ERJ3GEYJ 473 V (47 kΩ)
R14	7030003640	S. RESISTOR	ERJ3GEYJ 473 V (47 kΩ)
R15	7030003760	S. RESISTOR	ERJ3GEYJ 474 V (470 kΩ)
R16	7030003720	S. RESISTOR	ERJ3GEYJ 224 V (220 kΩ)
R17	7030003720	S. RESISTOR	ERJ3GEYJ 224 V (220 kΩ)
R18	7030003720	S. RESISTOR	ERJ3GEYJ 224 V (220 kΩ)
R19	7030003720	S. RESISTOR	ERJ3GEYJ 224 V (220 kΩ)
R20	7030003720	S. RESISTOR	ERJ3GEYJ 224 V (220 kΩ)
R21	7030003600	S. RESISTOR	ERJ3GEYJ 223 V (22 kΩ)
R22	7030003720	S. RESISTOR	ERJ3GEYJ 224 V (220 kΩ)
R23	7030003720	S. RESISTOR	ERJ3GEYJ 224 V (220 kΩ)
R24	7030003640	S. RESISTOR	ERJ3GEYJ 473 V (47 kΩ)
R26	7310003860	S. TRIMMER	EVM-3SSX50 BQ3 (472)
R27	7030003480	S. RESISTOR	ERJ3GEYJ 222 V (2.2 kΩ)
R28	7030003570	S. RESISTOR	ERJ3GEYJ 123 V (12 kΩ)
R29	7310003900	S. TRIMMER	EVM-3SSX50 B34 (303)
R31	7030003520	S. RESISTOR	ERJ3GEYJ 472 V (4.7 kΩ)
R32	7030003480	S. RESISTOR	ERJ3GEYJ 222 V (2.2 kΩ)
R33	7030003280	S. RESISTOR	ERJ3GEYJ 470 V (47 Ω)
R34	7030003620	S. RESISTOR	ERJ3GEYJ 333 V (33 kΩ)
R35	7030003550	S. RESISTOR	ERJ3GEYJ 822 V (8.2 kΩ)
R36	7030003530	S. RESISTOR	ERJ3GEYJ 562 V (5.6 kΩ)
R37	7030003640	S. RESISTOR	ERJ3GEYJ 473 V (47 kΩ)
R38	7030003640	S. RESISTOR	ERJ3GEYJ 473 V (47 kΩ)
R39	7030003600	S. RESISTOR	ERJ3GEYJ 223 V (22 kΩ)
R40	7030003600	S. RESISTOR	ERJ3GEYJ 223 V (22 kΩ)

[APC BOARD]

REF. NO.	ORDER NO.	DESCRIPTION	
Q1	1520000270	S. TRANSISTOR	2SB1182 TL Q
Q2	1530002280	S. TRANSISTOR	2SC4081 T107 S
Q3	1590000620	S. TRANSISTOR	FMS1 T148
Q4	1520000270	S. TRANSISTOR	2SB1182 TL Q
Q5	1530002280	S. TRANSISTOR	2SC4081 T107 S
D1	1160000050	S. DIODE	DAP202U T107
R2	7030003520	S. RESISTOR	ERJ3GEYJ 472 V (4.7 kΩ)
R3	7030003680	S. RESISTOR	ERJ3GEYJ 104 V (100 kΩ)
R4	7030003440	S. RESISTOR	ERJ3GEYJ 102 V (1 kΩ)
R6	7030003670	S. RESISTOR	ERJ3GEYJ 823 V (82 kΩ)
R8	7030003590	S. RESISTOR	ERJ3GEYJ 183 V (18 kΩ)
R9	7030003600	S. RESISTOR	ERJ3GEYJ 223 V (22 kΩ)
R10	7030003480	S. RESISTOR	ERJ3GEYJ 222 V (2.2 kΩ)
C1	4030006850	S. CERAMIC	C1608 JB 1H 471K-T-A
C2	4030006850	S. CERAMIC	C1608 JB 1H 471K-T-A
C5	4030006850	S. CERAMIC	C1608 JB 1H 471K-T-A
C6	4030006850	S. CERAMIC	C1608 JB 1H 471K-T-A
C7	4030006850	S. CERAMIC	C1608 JB 1H 471K-T-A
C8	4030006850	S. CERAMIC	C1608 JB 1H 471K-T-A
C9	4030008630	S. CERAMIC	C1608 JF 1C 104Z-T-A
EP1	0910041090	PCB	B 4136 (APC)
EP2	6910003110	LEADFRAME	HFB2.0-0.7-8 (N)

S.=Surface mount

[LOGIC UNIT]

REF. NO.	ORDER NO.	DESCRIPTION	
R41	7030003760	S. RESISTOR	ERJ3GEYJ 474 V (470 kΩ)
R42	7030003400	S. RESISTOR	ERJ3GEYJ 471 V (470 Ω)
R43	7030003560	S. RESISTOR	ERJ3GEYJ 103 V (10 kΩ)
R44	7030003440	S. RESISTOR	ERJ3GEYJ 102 V (1 kΩ)
R45	7030003450	S. RESISTOR	ERJ3GEYJ 122 V (1.2 kΩ)
R46	7030003440	S. RESISTOR	ERJ3GEYJ 102 V (1 kΩ)
R47	7030003400	S. RESISTOR	ERJ3GEYJ 471 V (470 Ω)
R48	7030003640	S. RESISTOR	ERJ3GEYJ 473 V (47 kΩ)
R49	7030003680	S. RESISTOR	ERJ3GEYJ 104 V (100 kΩ)
R50	7030003680	S. RESISTOR	ERJ3GEYJ 104 V (100 kΩ)
R51	7030003710	S. RESISTOR	ERJ3GEYJ 184 V (180 kΩ)
R52	7030003650	S. RESISTOR	ERJ3GEYJ 563 V (56 kΩ)
R53	7030003560	S. RESISTOR	ERJ3GEYJ 103 V (10 kΩ)
R54	7030003640	S. RESISTOR	ERJ3GEYJ 473 V (47 kΩ)
C1	4030006640	S. CERAMIC	C1608 SL 1H 180J-T-A
C2	4030006640	S. CERAMIC	C1608 SL 1H 180J-T-A
C3	4550000770	S. TANTALUM	TESVC 0J 226M-12L
C4	4030006860	S. CERAMIC	C1608 JB 1H 102K-T-A
C5	4030008920	S. CERAMIC	C1608 JB 1C 473K-T-A
C6	4030008630	S. CERAMIC	C1608 JF 1C 104Z-T-A
C7	4030008630	S. CERAMIC	C1608 JF 1C 104Z-T-A
C8	4030006850	S. CERAMIC	C1608 JB 1H 471K-T-A
C9	4030006860	S. CERAMIC	C1608 JB 1H 102K-T-A
C10	4030006860	S. CERAMIC	C1608 JB 1H 102K-T-A
C11	4030008630	S. CERAMIC	C1608 JF 1C 104Z-T-A
C12	4030006850	S. CERAMIC	C1608 JB 1H 471K-T-A
C13	4030006850	S. CERAMIC	C1608 JB 1H 471K-T-A
C14	4030006860	S. CERAMIC	C1608 JB 1H 102K-T-A
C15	4030006860	S. CERAMIC	C1608 JB 1H 102K-T-A
C16	4030008630	S. CERAMIC	C1608 JF 1C 104Z-T-A
C17	4030008630	S. CERAMIC	C1608 JF 1C 104Z-T-A
C18	4030008630	S. CERAMIC	C1608 JF 1C 104Z-T-A
C19	4030006860	S. CERAMIC	C1608 JB 1H 102K-T-A
C20	4030006860	S. CERAMIC	C1608 JB 1H 102K-T-A
C21	4550003040	S. TANTALUM	TEMSVB2 0J 106M-8L
C22	4030006860	S. CERAMIC	C1608 JB 1H 102K-T-A
C23	4030006860	S. CERAMIC	C1608 JB 1H 102K-T-A
C24	4030006860	S. CERAMIC	C1608 JB 1H 102K-T-A
C25	4030008630	S. CERAMIC	C1608 JF 1C 104Z-T-A
C26	4030008630	S. CERAMIC	C1608 JF 1C 104Z-T-A
C27	4030008630	S. CERAMIC	C1608 JF 1C 104Z-T-A
C28	4030006860	S. CERAMIC	C1608 JB 1H 102K-T-A
C29	4030006860	S. CERAMIC	C1608 JB 1H 102K-T-A
C30	4030008630	S. CERAMIC	C1608 JF 1C 104Z-T-A
DS1	5030000950	LCD	LD-BU5579J (E-5777)
DS2	5040001260	LED	LN01301C (Q)
DS3	5040001260	LED	LN01301C (Q)
S1	2260001560	S. SWITCH	SW-131 (SKHMPU) [DUAL/SCAN LOCKOUT]
S2	2260001560	S. SWITCH	SW-131 (SKHMPU) [16]
S3	2260001560	S. SWITCH	SW-131 (SKHMPU) [C]
S4	2220000500	S. SWITCH	SW-141 (SSSS81)
S5	2260001560	S. SWITCH	SW-131 (SKHMPU) [MEMO/MW]
S6	2260001560	S. SWITCH	SW-131 (SKHMPU) [LIGHT/SCRM LOCK]
MC1	7700001750	MICROPHONE	EM-123TH
J1	6510003550	CONNECTOR	S07B-EH-S
J3	6510007860	CONNECTOR	PI28A-07M
J4	6510009460	CONNECTOR	S2B-ZR
J5	6510016610	S. CONNECTOR	52396-3090
EP1	0910040872	PCB	B 4058B (LOGIC)
EP2	8930014860	LCD CONTACT	SRCN-752 SG-TYPE

[PTT UNIT]

REF. NO.	ORDER NO.	DESCRIPTION	
R1	7030003280	S. RESISTOR	ERJ3GEYJ 470 V (47 Ω)
S1	2230000770	S. SWITCH	SW-104 (SKHUPE004B) [HI/LO]
S2	2230000770	S. SWITCH	SW-104 (SKHUPE004B) [PTT]
J1	6510007090	CONNECTOR	PI28A-04M
EP1	0910040862	PCB	B 4059B (PTT)

[SENSOR UNIT]

REF. NO.	ORDER NO.	DESCRIPTION	
C1	4030006850	S. CERAMIC	C1608 JB 1H 471K-T-A
C2	4030006850	S. CERAMIC	C1608 JB 1H 471K-T-A
S1	7210002480	ENCODER	TP90N97E20-15F [CHANNEL]
EP1	0910040852	PCB	B 4060B (SENSOR)

[VR UNIT]

REF. NO.	ORDER NO.	DESCRIPTION	
R1	7210002490		TP96N97N15F-10KA [OFF/VOL]
R2	7210002500		TP96N97-15F-10KB [SQL]
C1	4510004990	ELECTROLYTIC	16 MV 100 HC
C2	4030006860	S. CERAMIC	C1608 JB 1H 102K-T-A
C3	4030006860	S. CERAMIC	C1608 JB 1H 102K-T-A
J1	6510007170	CONNECTOR	PI28A-03M
J2	6510007090	CONNECTOR	PI28A-04M
EP1	0910040841	PCB	B 4061A (VR)

S. = Surface mount

[JACK UNIT]

REF. NO.	ORDER NO.	DESCRIPTION	
C1	4030006860	S. CERAMIC	C1608 JB 1H 102K-T-A
C2	4030006890	S. CERAMIC	C1608 JF 1H 103Z-T-A
J1	6510016710	CONNECTOR	YM-263
EP1	0910040831	PCB	B 4062A (JACK)

[SCRMN UNIT]

REF. NO.	ORDER NO.	DESCRIPTION	
R1	7030003450	S. RESISTOR	ERJ3GEYJ 122 V (1.2 kΩ)
C1	4030008680	S. CERAMIC	C2012 JF 1C 105Z-T-A
C2	4030008680	S. CERAMIC	C2012 JF 1C 105Z-T-A
C3	4030008680	S. CERAMIC	C2012 JF 1C 105Z-T-A
C4	4030008680	S. CERAMIC	C2012 JF 1C 105Z-T-A
EP1	0910041110	PCB	B 4138 (SCRMN)

S.=Surface mount

SECTION 6

MECHANICAL PARTS AND DISASSEMBLY

• CHASSIS PARTS

LABEL NUMBER	ORDER NO.	DESCRIPTION	QTY.
①	8930014870	752 LCD holder	1
②	5030000950	LCD LD-BU5579J (E-5777)	1
③	8930014860	LCD contact SRCN-752 SG-type	1
④	8810004850	Screw PH No. 0 M2 × 4	12
⑤	8930030020	1301 module holder	1
⑥	8510008240	1416 PLL case	1
⑦	8930026510	Aluminum sheet S	1
⑧	8510008210	1416 PLL cover	1
⑨	8510005830	CO-PLL cover	1
⑩	8610008850	Knob N208 [SQL, OFF/VOL]	2
⑪	8810007990	Screw FH M2 × 4 SUS ZK	1
⑫	6510016530	Connector [ANT] (incl. ground lug, nut)	1
⑬	8610008860	Knob N209 [CHANNEL]	1
⑭	8830000910	1301 VR nut	3
⑮	8930028880	O-ring (M)	3
⑯	8210009620	1301 top panel/chassis	1
⑰	8810008000	Screw PH No. 0 M2.6 × 6	2
⑱	7210002500	Variable resistor TP96N97-15F-10KB [SQL]	1
⑲	7210002490	Variable resistor TP96N97N15F-10KA [OFF/VOL]	1
⑳	7210002480	Encoder TP90N97E20-15F [CHANNEL]	1
㉑	8930031490	1301 seal	1
㉒	6510016710	Jack YM-263	1
㉓	8810008010	Screw PH No. 0-3 M1.6 × 4	3
㉔	8210010450	Outer case for USA (incl. Speaker)	1
	8210010460	Outer case for EUR (incl. Speaker)	
	8210010470	Outer case for UK (incl. Speaker)	

Screw abbreviations PH: Pan head FH: Flat head SUS: Stainless ZK: Black

• ACCESSORIES

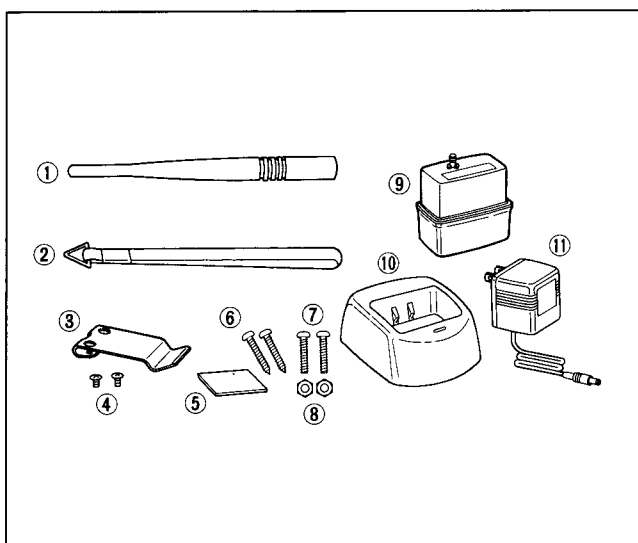

LABEL NUMBER	ORDER NO.	DESCRIPTION	QTY.
①	Optional product	FA-S54V FLEXIBLE ANTENNA	1
②	801001537	Handstrap HK-008	1
③	801000571	Belt clip	1
④	881000573	Screw BuH M3 × 3 ZK BS	2
⑤	893002869	Sheet AG	2
⑥	881000505	Screw PH A M4 × 20 SUS	2
⑦	881000067	Screw PH M4 × 15 SUS	2
⑧	883000024	Nut M4 SUS	2
⑨	Optional product	CM-138 BATTERY PACK	1
⑩	Optional product	AD-43 BATTERY CHARGE ADAPTER	1
⑪	Optional product	BM-95U AC ADAPTER (USA)	1
	Optional product	BM-95E AC ADAPTER (EUR)	
	—	No charger is supplied (UK)	

Screw abbreviations BuH: Button head BS: Brass
ZK: Black PH: Pan head
SUS: Stainless

NOTE 2:

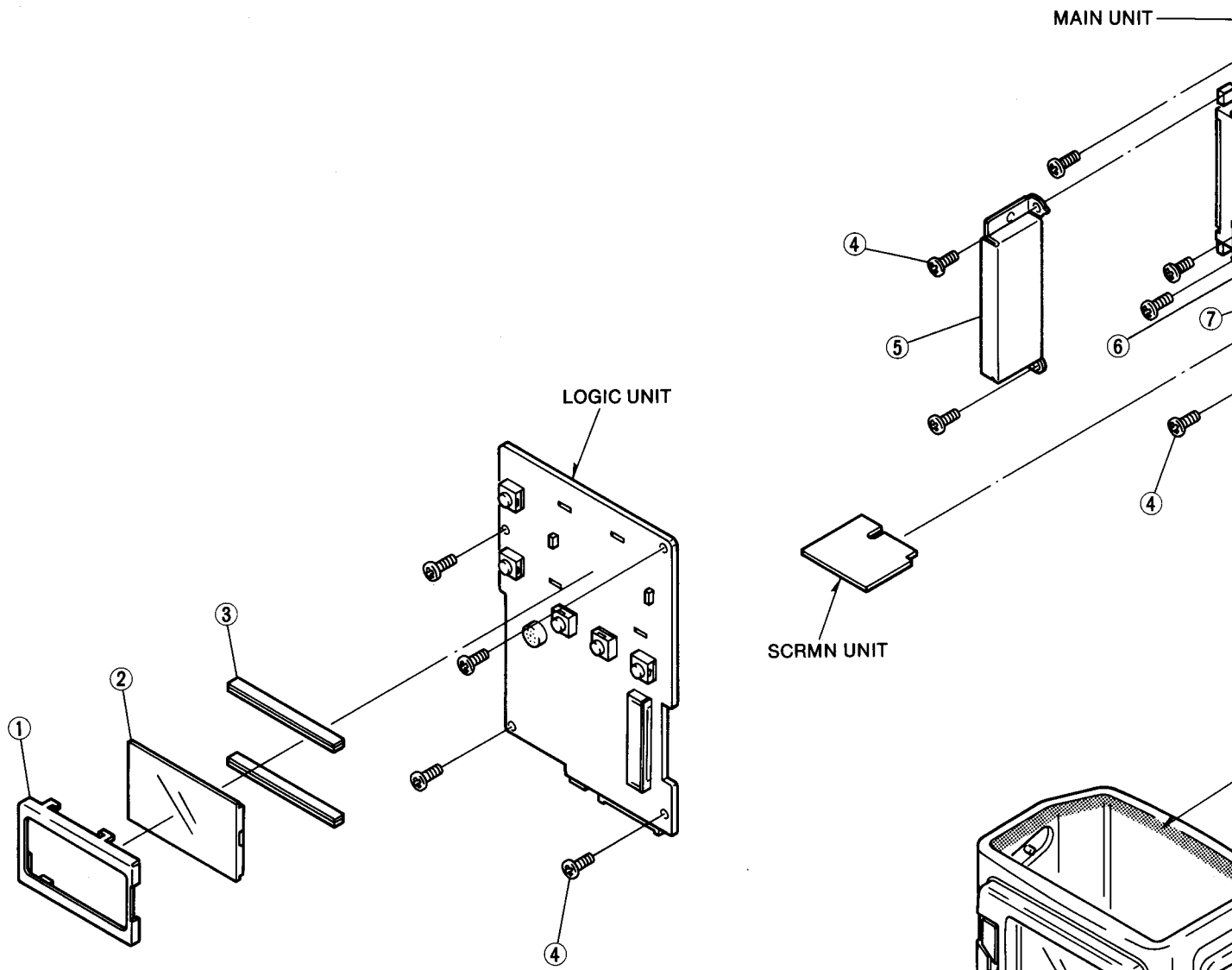

NOTE 1:

Once the VR nuts ⑭ are removed, grease must be applied and O-ring ⑲ must be inserted correctly.

1. Apply grease to the gap at the variable resistor's shank base.

Manufacture: Shin-Etsu Chemical

Type: G-501

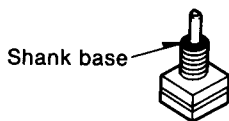

2. O-ring ⑲ must be inserted into concentric space of VR-nut ⑭ then gently poke along the entire diameter of ⑲ with a tweezers to ensure it is fully inserted. This procedure should be followed for each of the 3 O-rings to ensure watertightness.

NOTE 2:

Be careful when reattaching ⑳ (1540 seal). This seal must fit snugly between the top panel and transceiver chassis (be sure to observe the correct orientation) to ensure water-tightness. Once the seal is removed, grease must be applied before assembly.

Manufacture: Shin-Etsu Chemical

Type: G-501

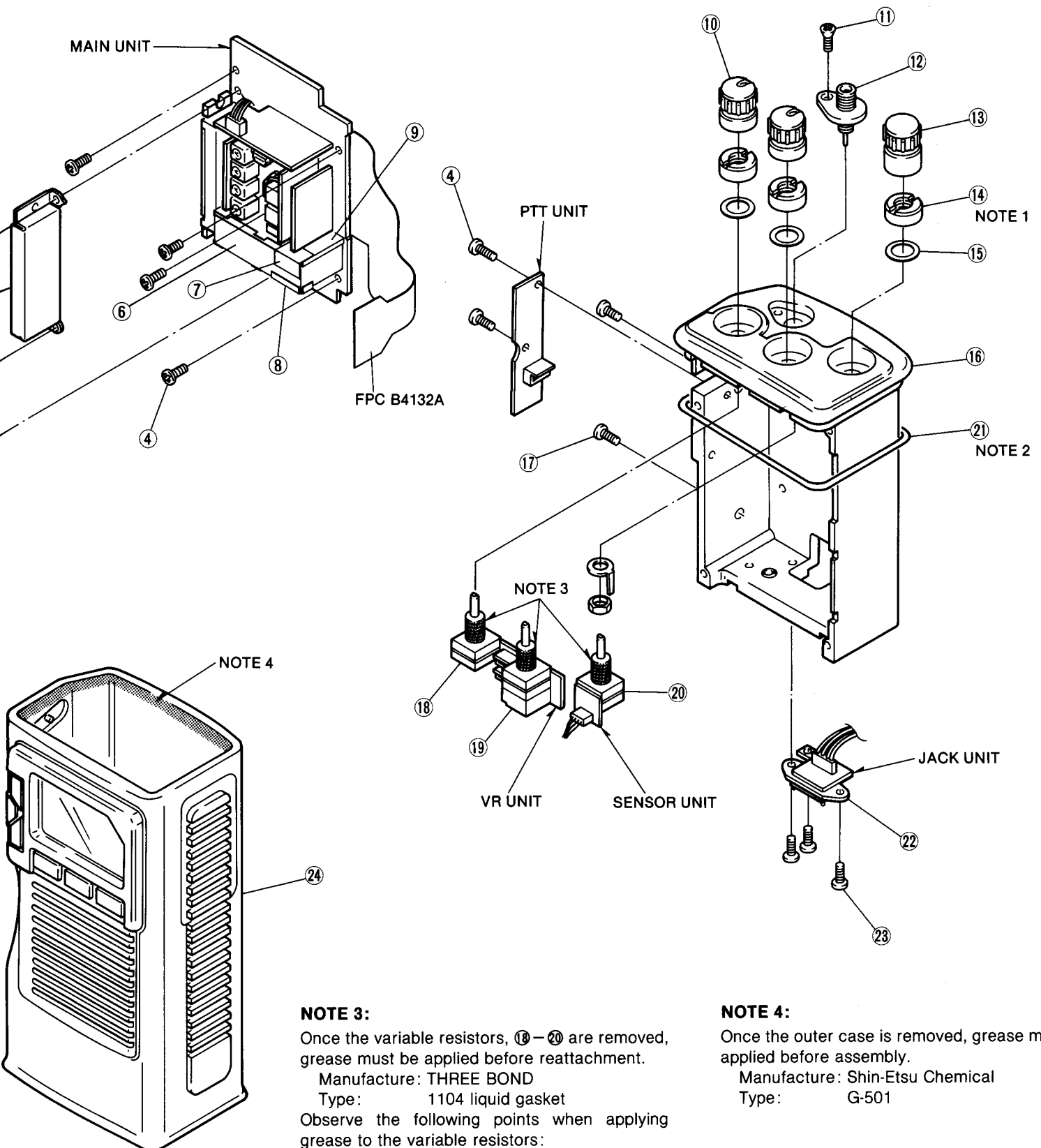

NOTE 3:

Once the variable resistors, ⑱—⑳ are removed, grease must be applied before reattachment.

Manufacture: THREE BOND

Type: 1104 liquid gasket

Observe the following points when applying grease to the variable resistors:

1. When replacing to new resistors, grease applying is not necessary, however, observe item 3.
2. Use a soft-tipped painter's brush and apply grease to the threaded part of the resistors ONLY.
3. Leave the variable resistors in an upright position for 12 hours to let the grease set.
4. Make sure no grease is applied to the moving part of the resistors: the grease will bond here making movement impossible.

NOTE 4:

Once the outer case is removed, grease must be applied before assembly.

Manufacture: Shin-Etsu Chemical

Type: G-501

SECTION 7 BOARD LAYOUTS

7-1 PTT, VR, SENSOR, JACK AND SCRMN UNITS

• PTT UNIT

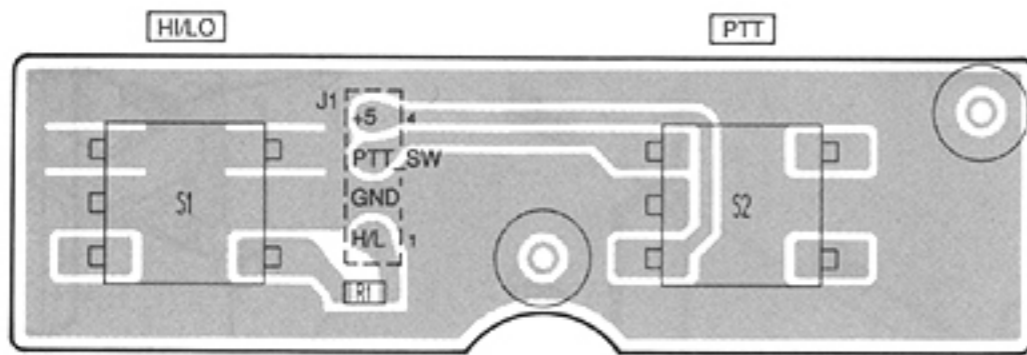

• VR UNIT

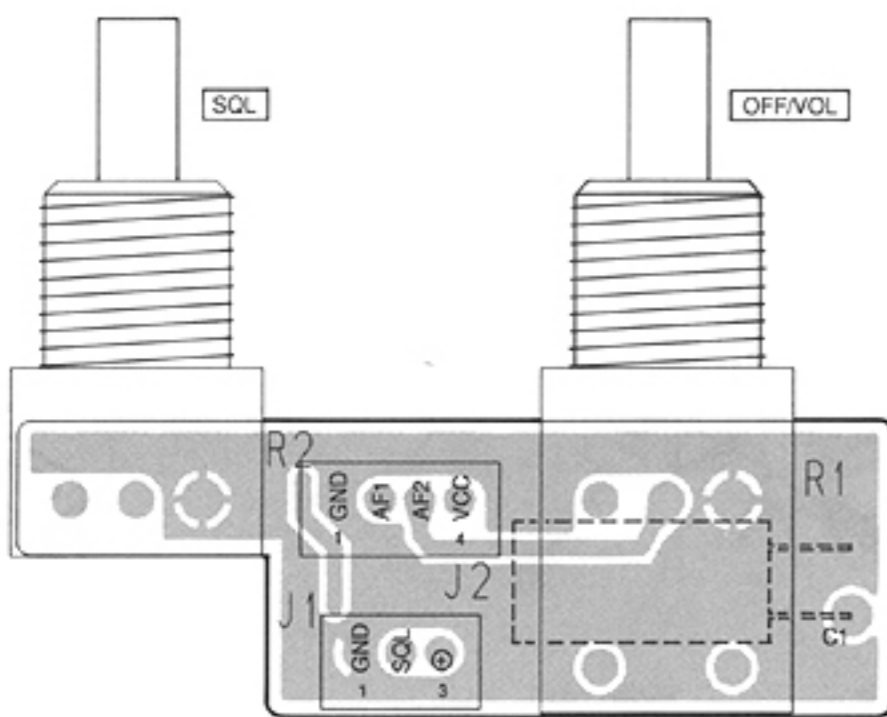

• SENSOR UNIT

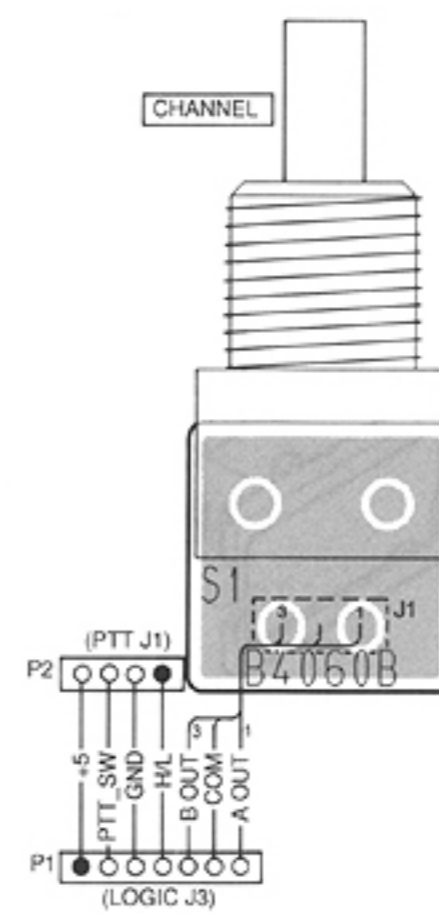

• JACK UNIT

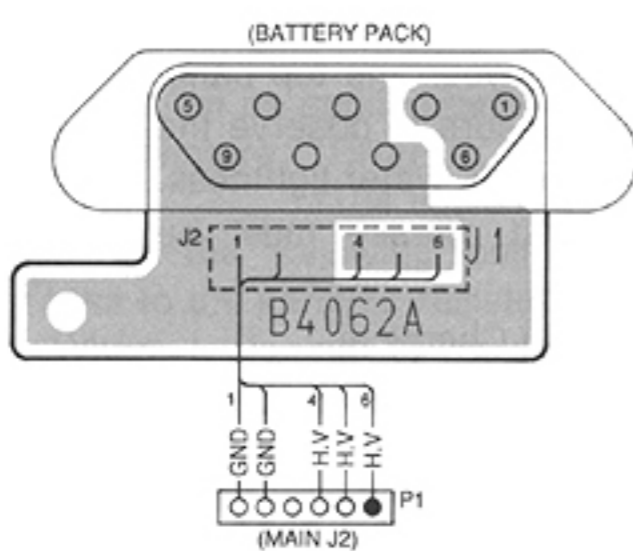

• SCRMN UNIT

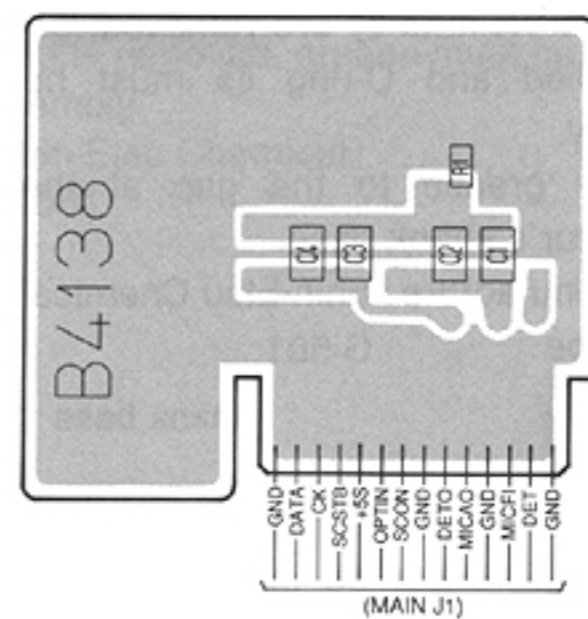

7-2 LOGIC UNIT

• LOGIC UNIT

The combination of this page and the next page show the unit layout in the same configuration as the actual P.C. Board.

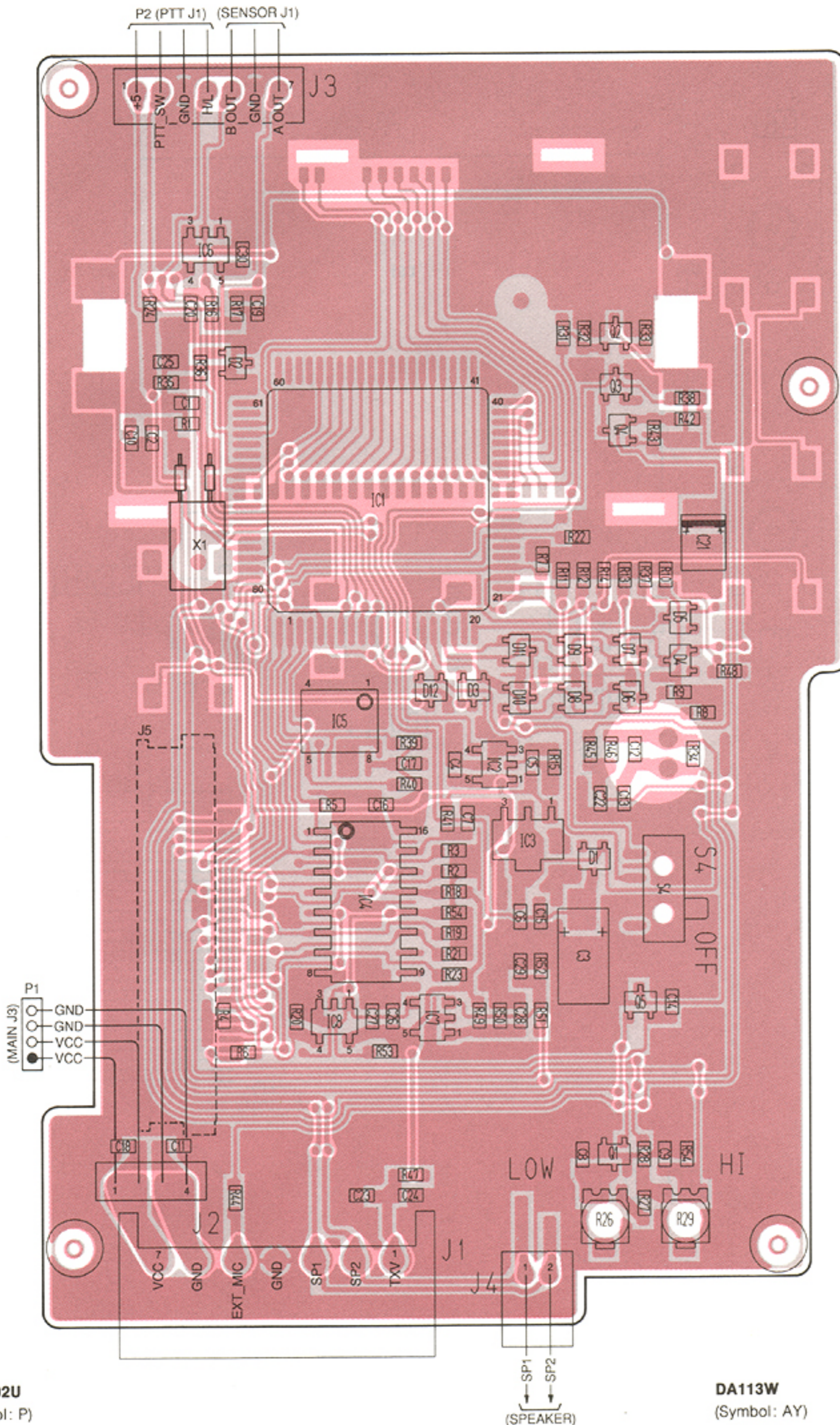

DTC144EU
(Symbol: 26)

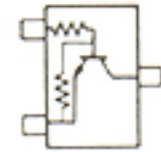

Q1, Q3, Q5

2SC4081 R
(Symbol: BR)

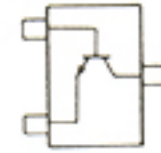

Q2

2SA1576 R
(Symbol: FR)

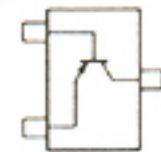

Q4

DA114
(Symbol: AV)

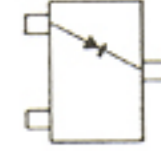

D1

DA204U
(Symbol: K)

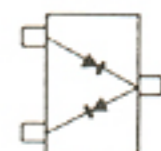

D2

DA112
(Symbol: AZ)

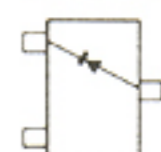

D3, D6 (#03), D7 (#02, #03), D12

DAP202U
(Symbol: P)

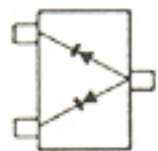

D6 (#02),
D10 (#02, #03)

DA113W
(Symbol: AY)

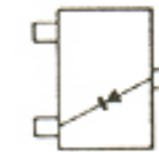

D8 (#02, #03),
D9 (#02), D10 (#01)

DA115
(Symbol: AU)

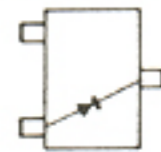

D4, D5

• LOGIC UNIT

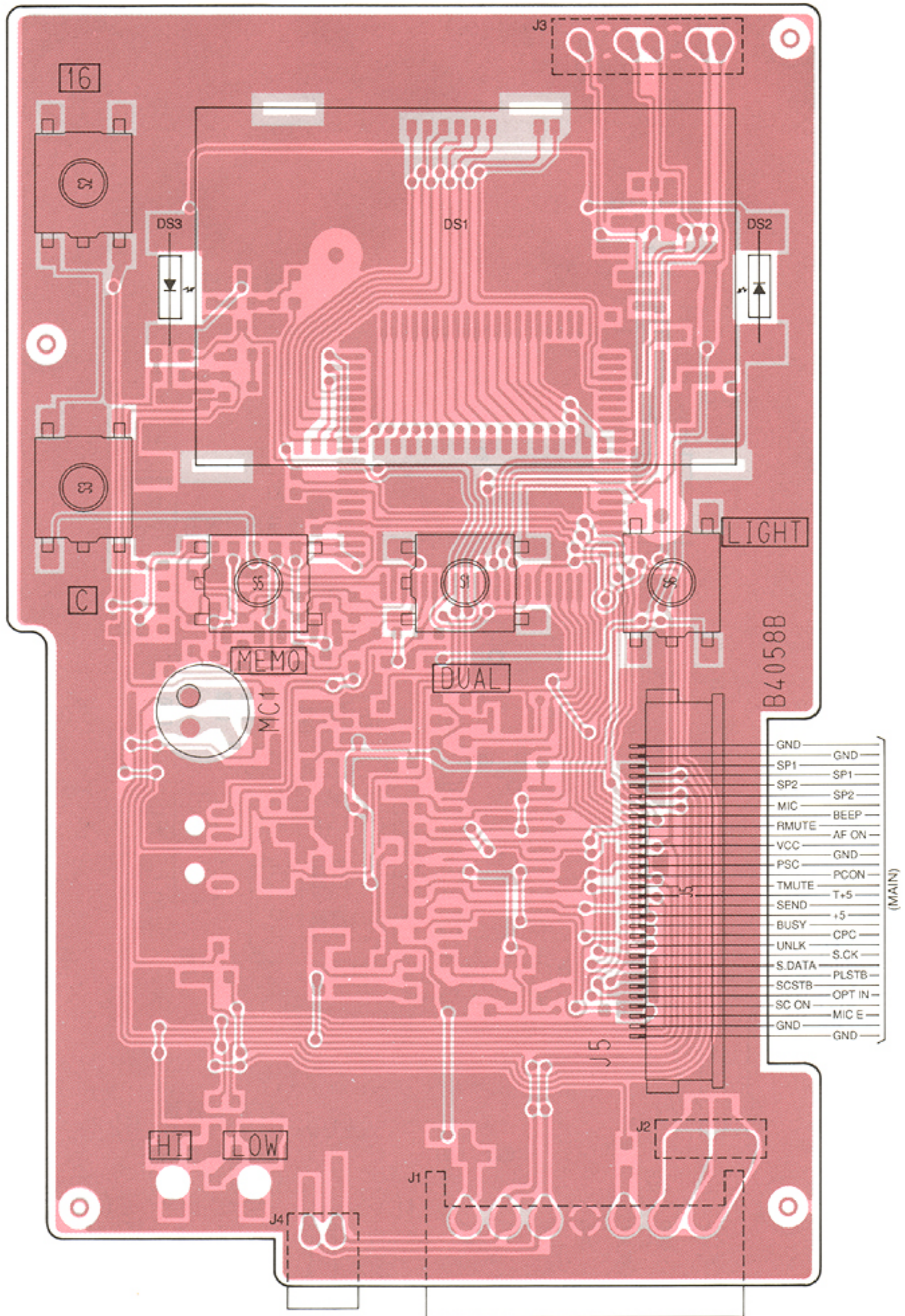

7-3 MAIN UNIT

• MAIN UNIT

The combination of this page and the next page show the unit layout in the same configuration as the actual P.C. Board.

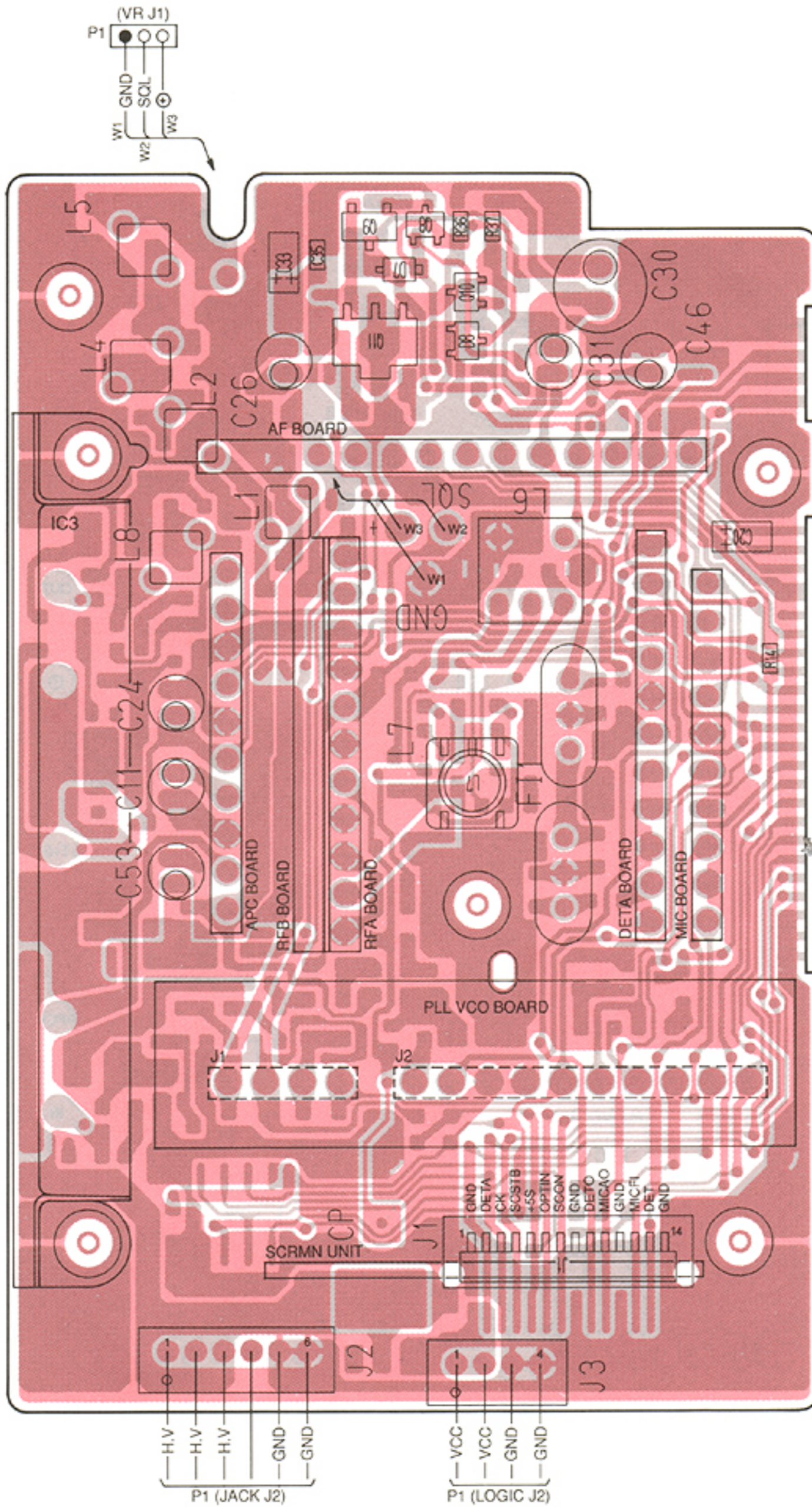

2SC4081 S
(Symbol: BS)

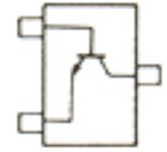

Q8, Q10

2SA1162 GR
(Symbol: SG)

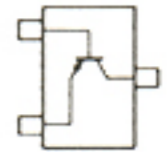

Q9

2SB798 DK
(Symbol: DK)



Q11

DAN202U
(Symbol: N)

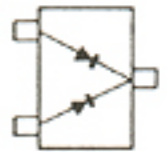

D8

• MAIN UNIT

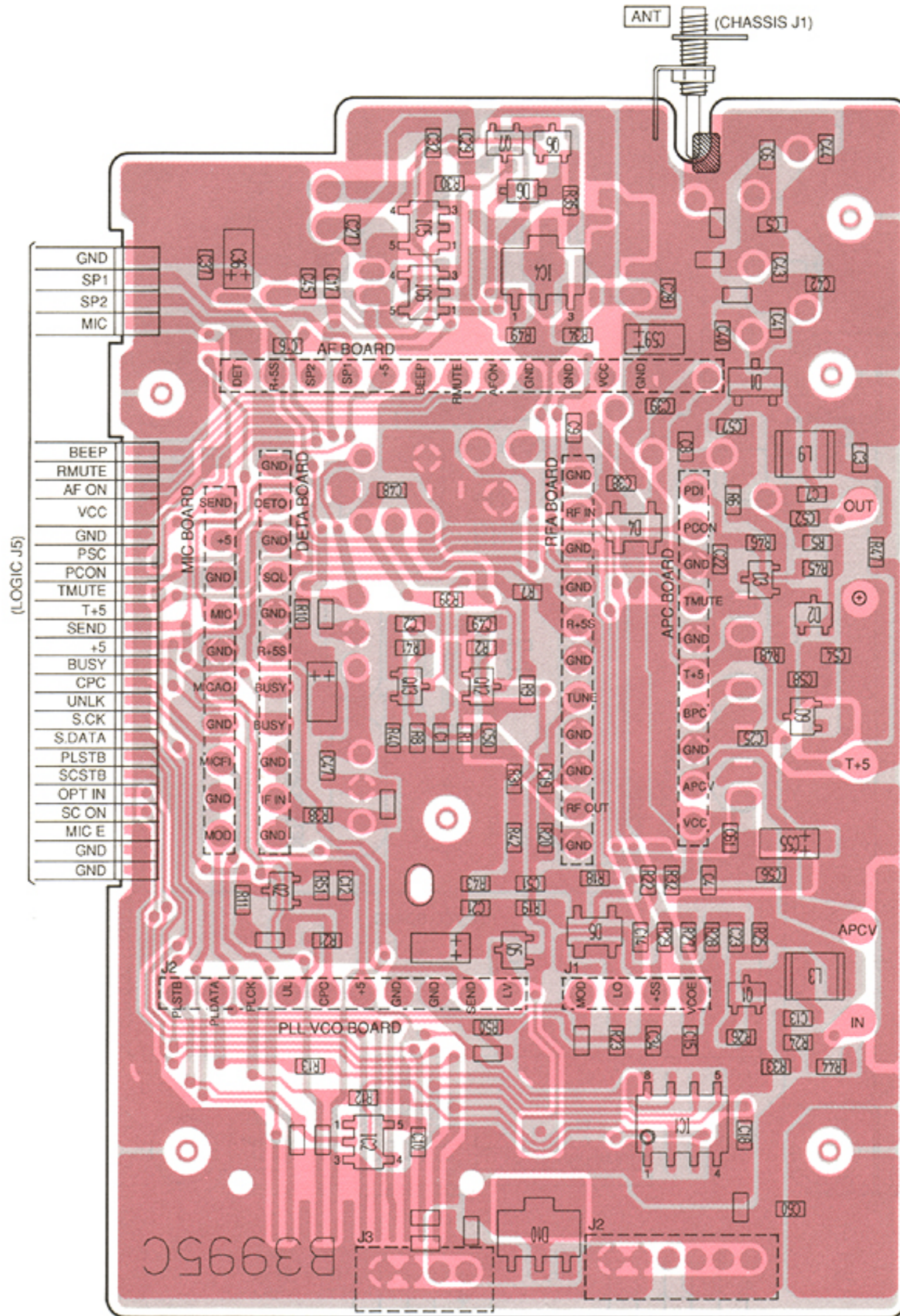

2SC4226 R25
(Symbol: R25)

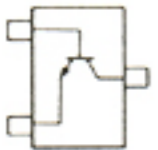

Q1, Q12, Q13

2SA1576 R
(Symbol: FR)

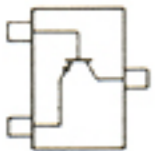

Q2, Q7

2SK880 Y
(Symbol: XY)



Q5

2SC4081 S
(Symbol: BS)

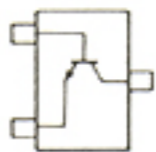

Q6

1SS153
(Symbol: A9)

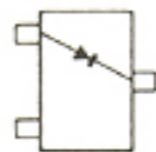

D1

MA742
(Symbol: M1U)

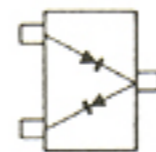

D2, D3, D9

MA862
(Symbol: M1I)

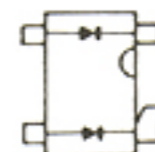

D4, D5

SB30 03P TD
(Symbol: SG)

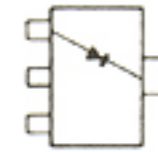

D10

• AF BOARD

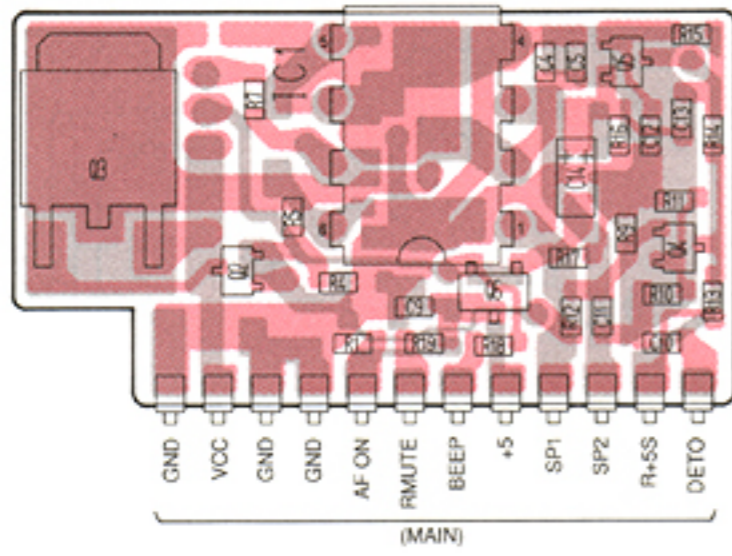

2SC4081 S
(Symbol: BS)

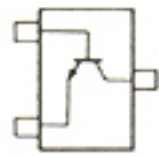

Q2, Q4, Q5

2SB1182

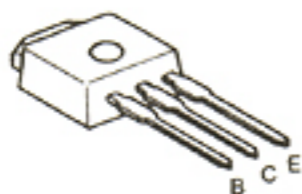

Q3



2SJ106 GR
(Symbol: VG)

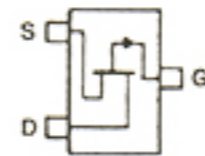

Q6

• APC BOARD

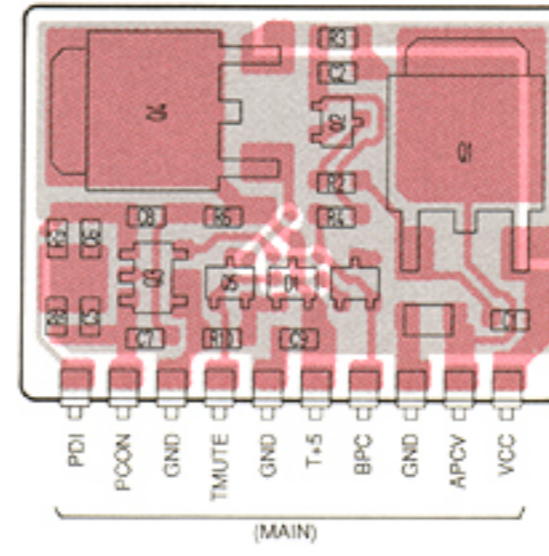

2SB1182

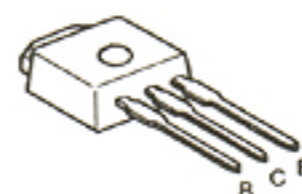

Q1, Q4



2SC4081 S
(Symbol: BS)

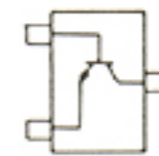

Q2, Q5

FMS1
(Symbol: SI)

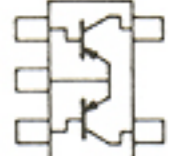

Q3

DAP202U
(Symbol: P)

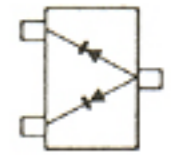

D1

• RFA BOARD

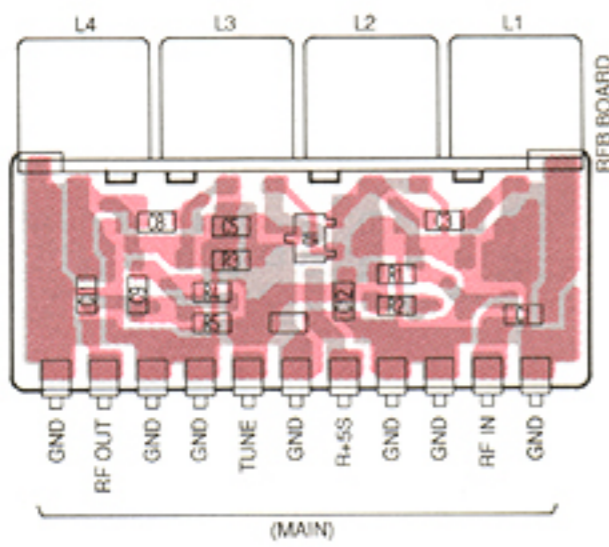

2SK882 Y
(Symbol: TY)



Q1

• DETA BOARD

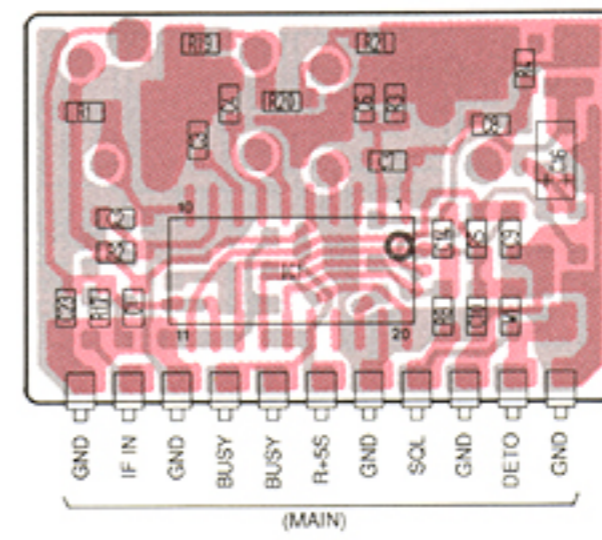

• PLL VCO BOARD

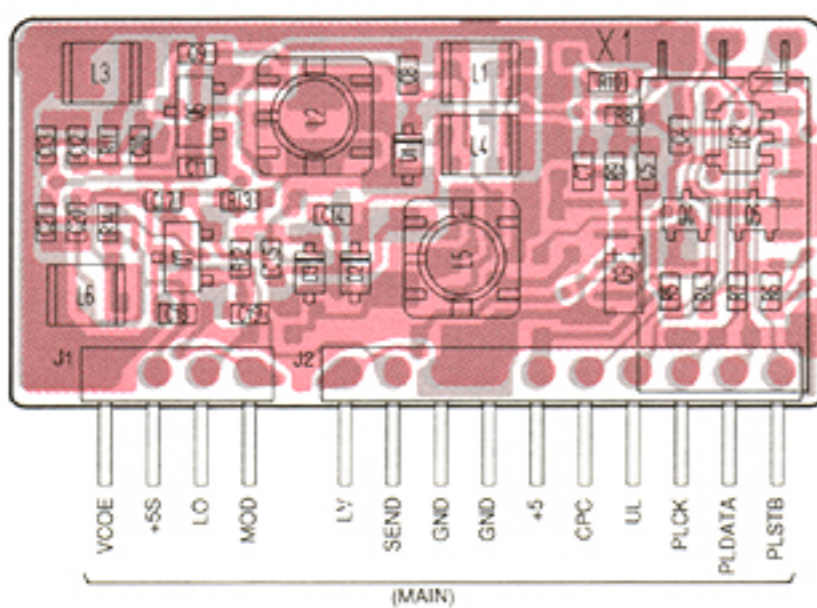

MA363B
(Symbol: 6D)



D1, D2, D3

• MIC BOARD

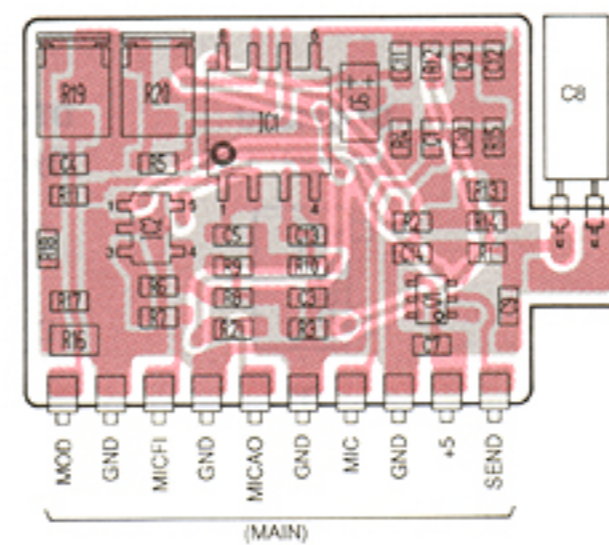

XP4312
(Symbol: 7T)

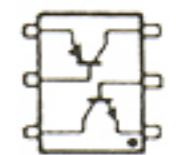

Q1

2SA1576 S
(Symbol: FS)

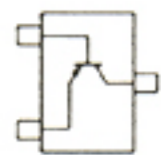

Q4

2SC4081 S
(Symbol: BS)

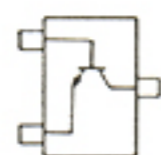

Q5

2SK210 Y
(Symbol: YY)

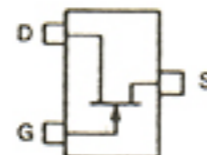

Q6

2SK210 GR
(Symbol: YG)

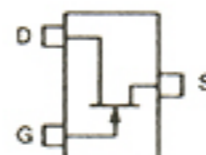

Q7

• AF BOARD

2SC4081 S
(Symbol: BS)

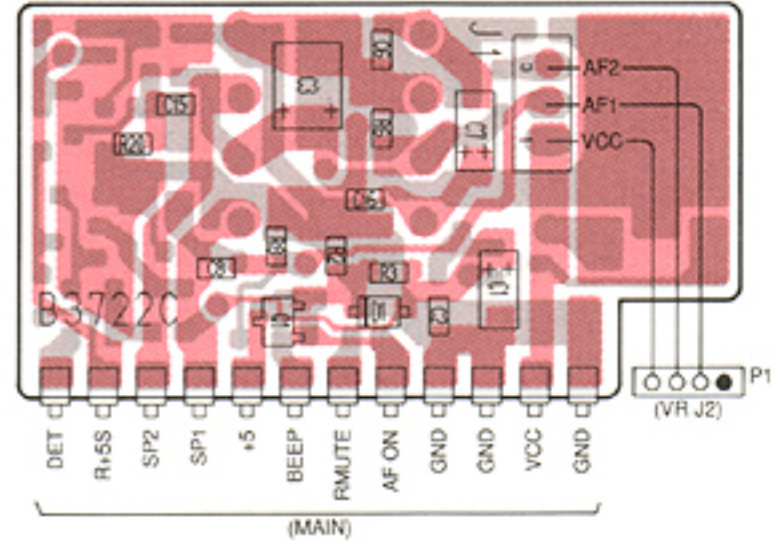
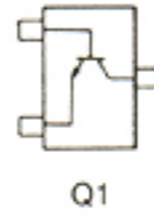

• DETA BOARD

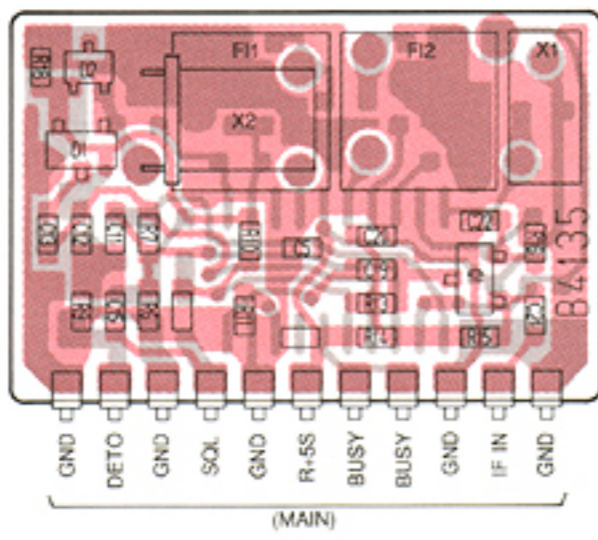

• RFA BOARD

MA363B
(Symbol: 6D)

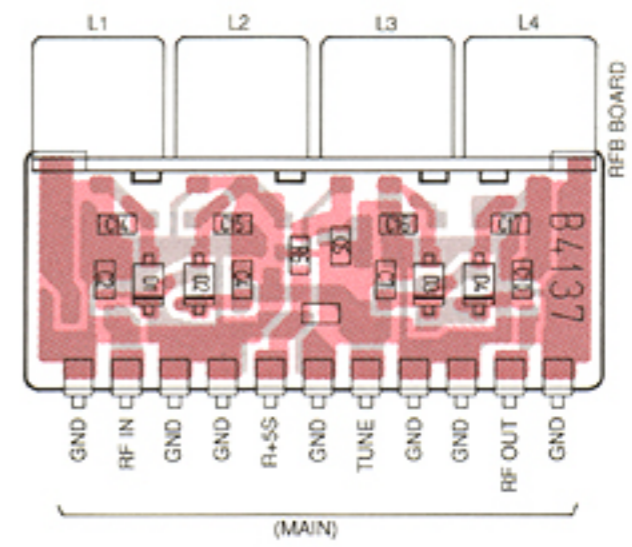
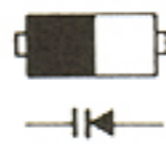

2SC3770 3
(Symbol: JY3)

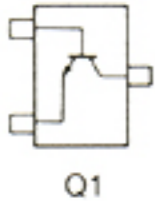

HSM88AS
(Symbol: C1)

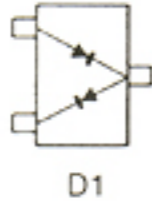

DA204U
(Symbol: K)

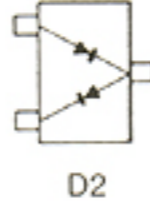

• PLL VCO BOARD

DTA143ZU
(Symbol: 113)

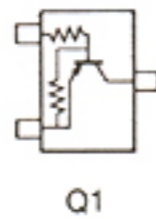

DTC144EU
(Symbol: 26)

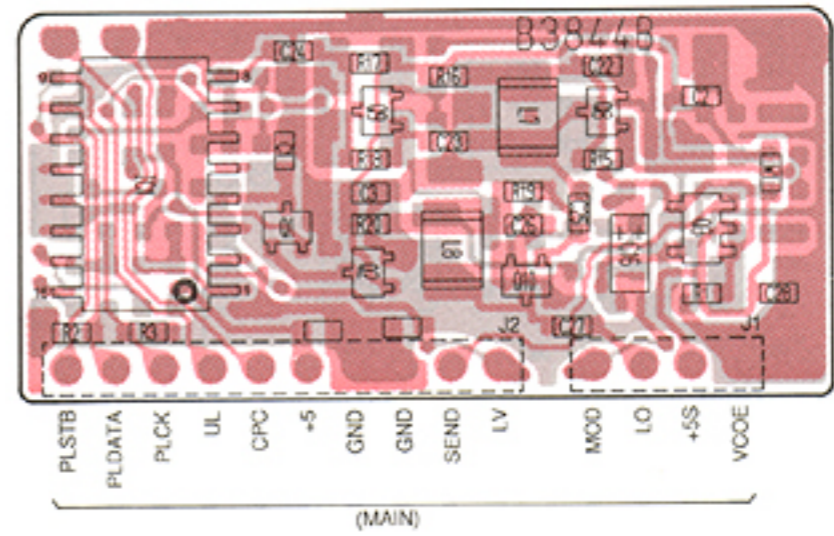
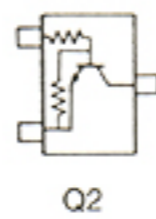

FMA2
(Symbol: A2)

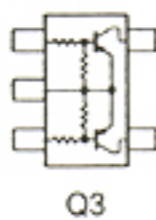

2SC4215 0
(Symbol: Q0)



SECTION 8 OPTIONAL UNIT

• UT-79 VOICE SCRAMBLER UNIT

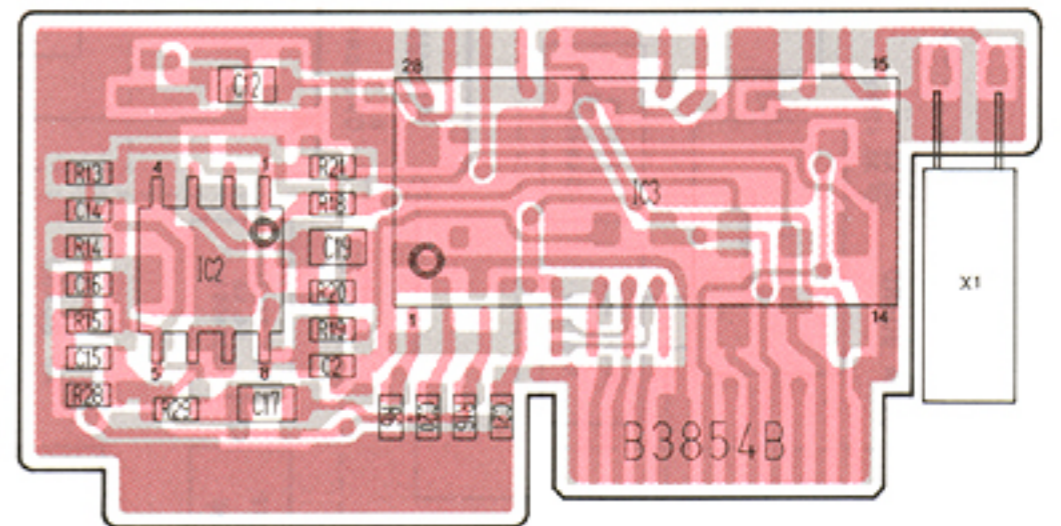
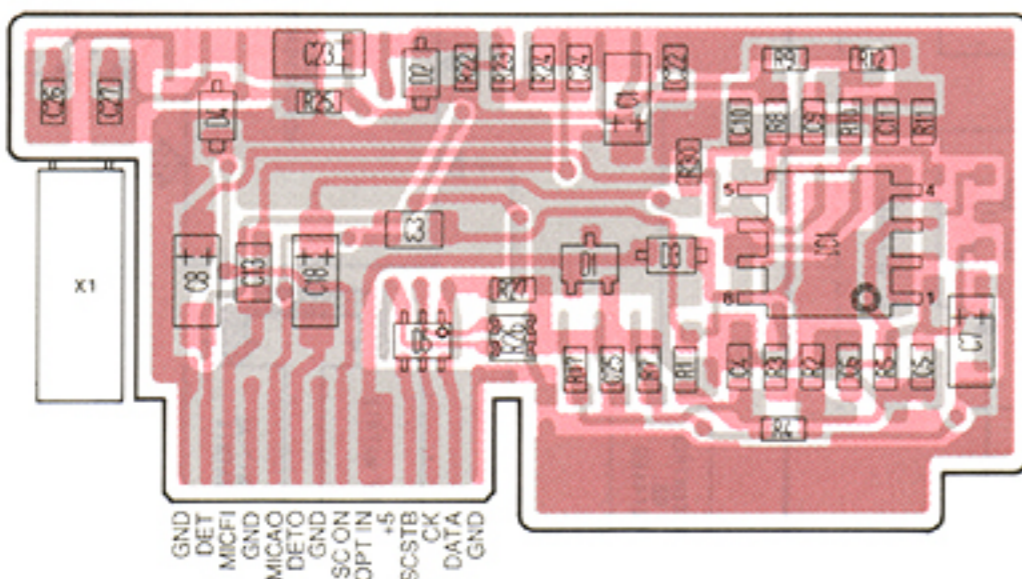
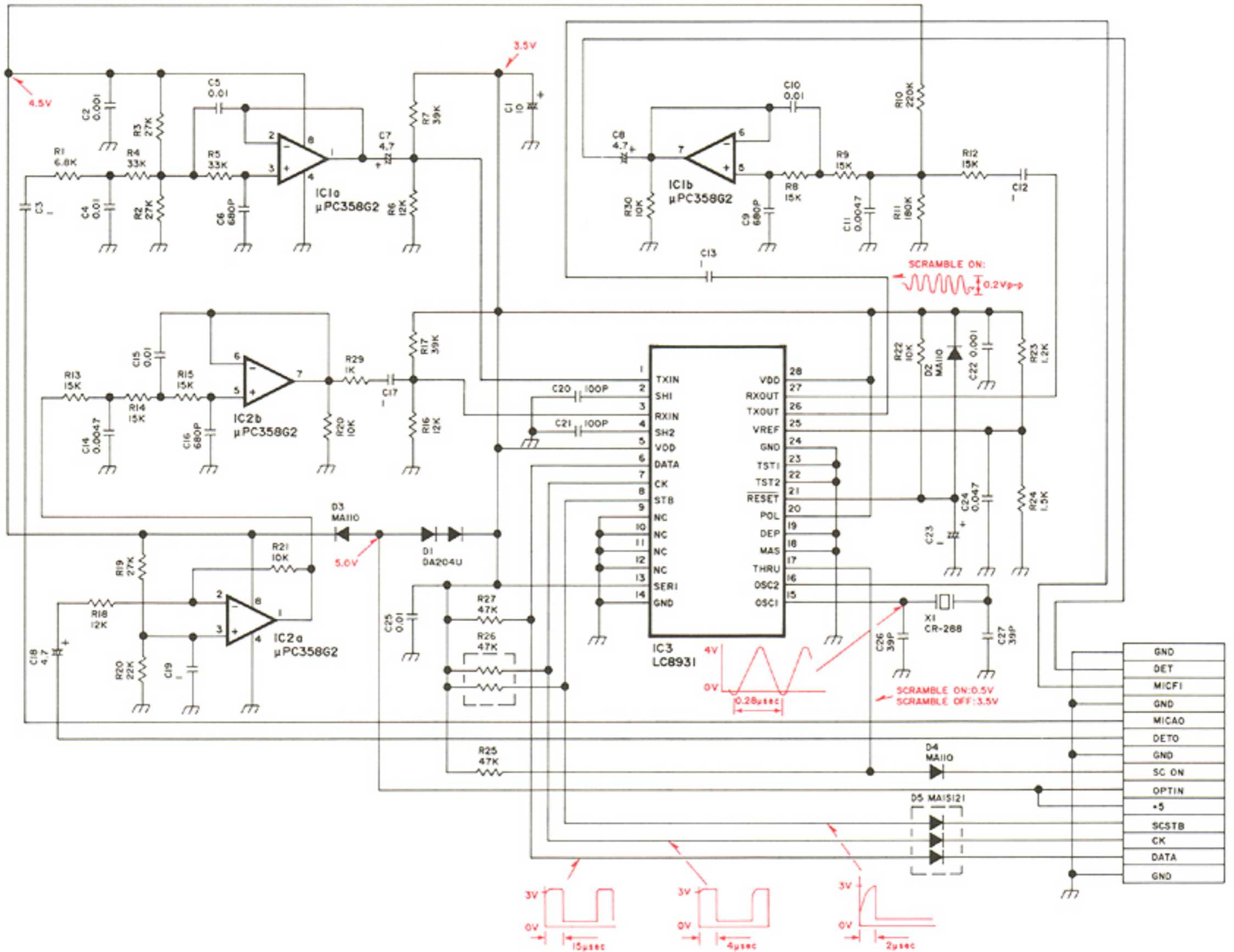

SECTION 9 BLOCK DIAGRAM

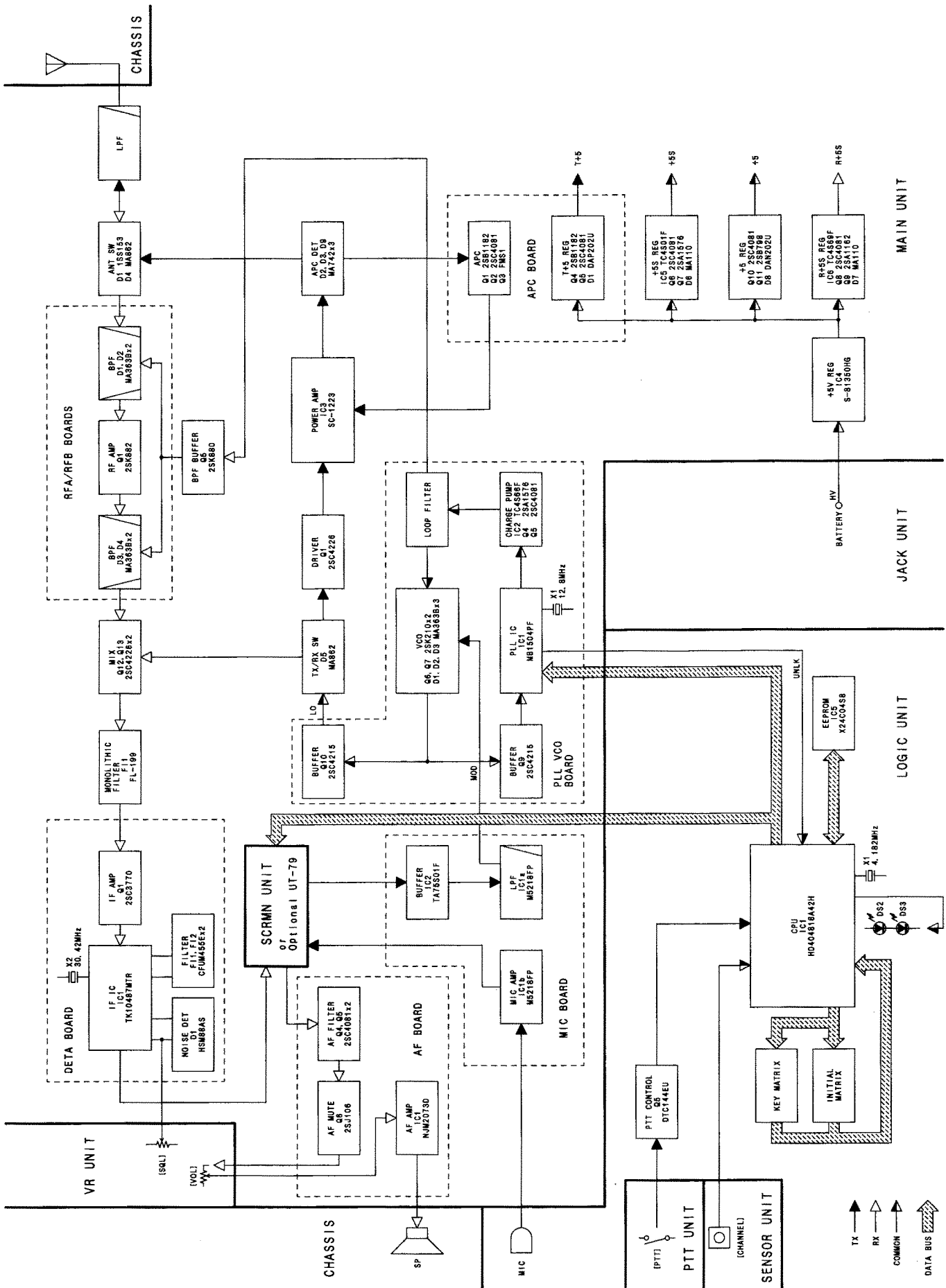

SECTION 10 VOLTAGE DIAGRAM

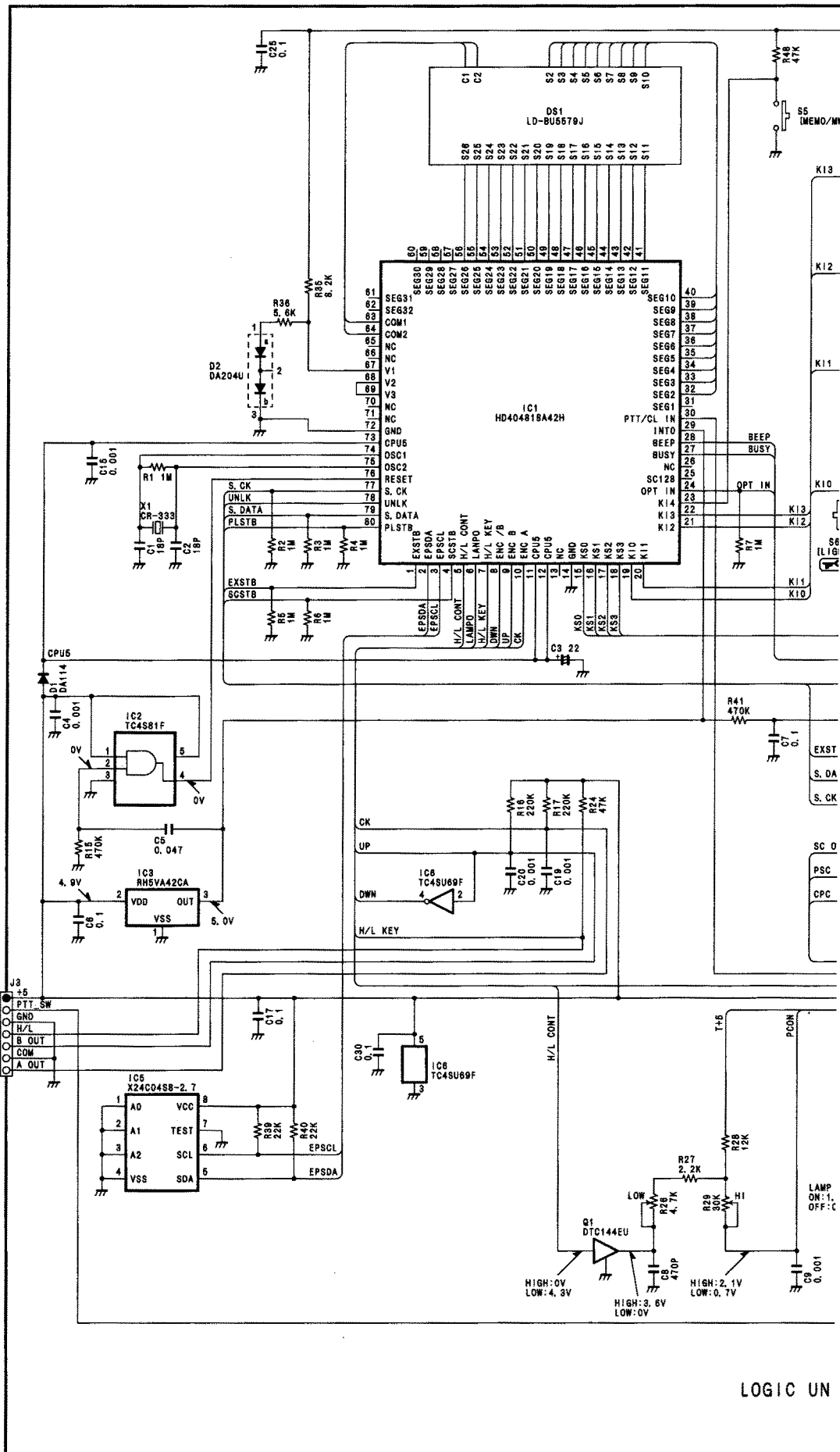
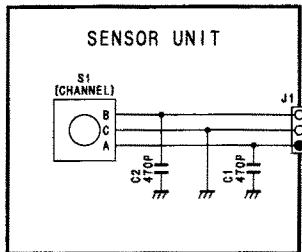
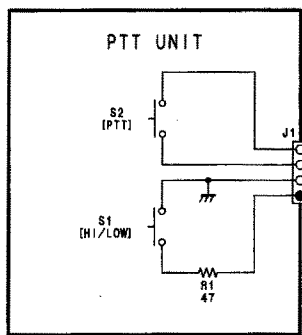

LOGIC UN

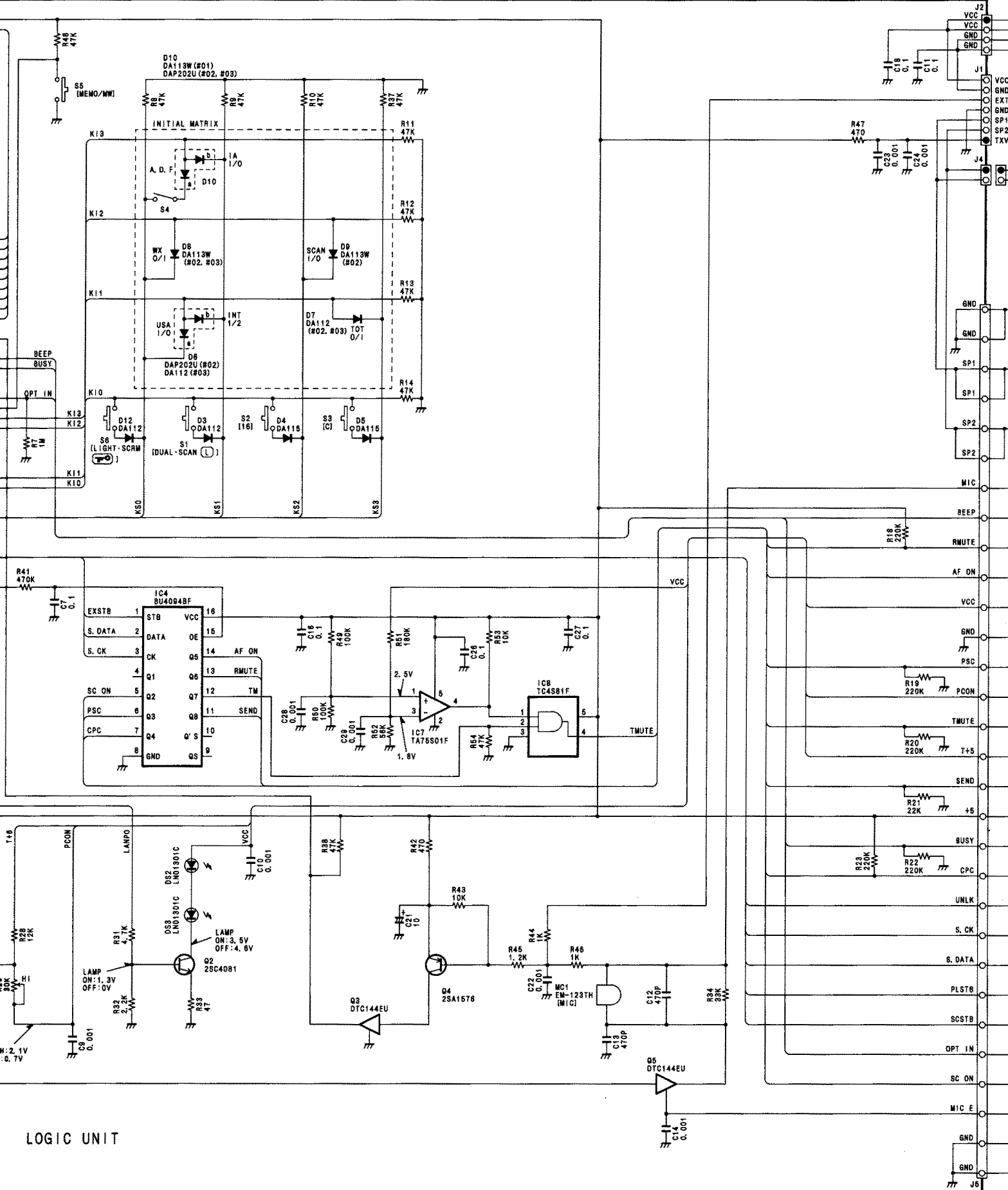

LOGIC UNIT

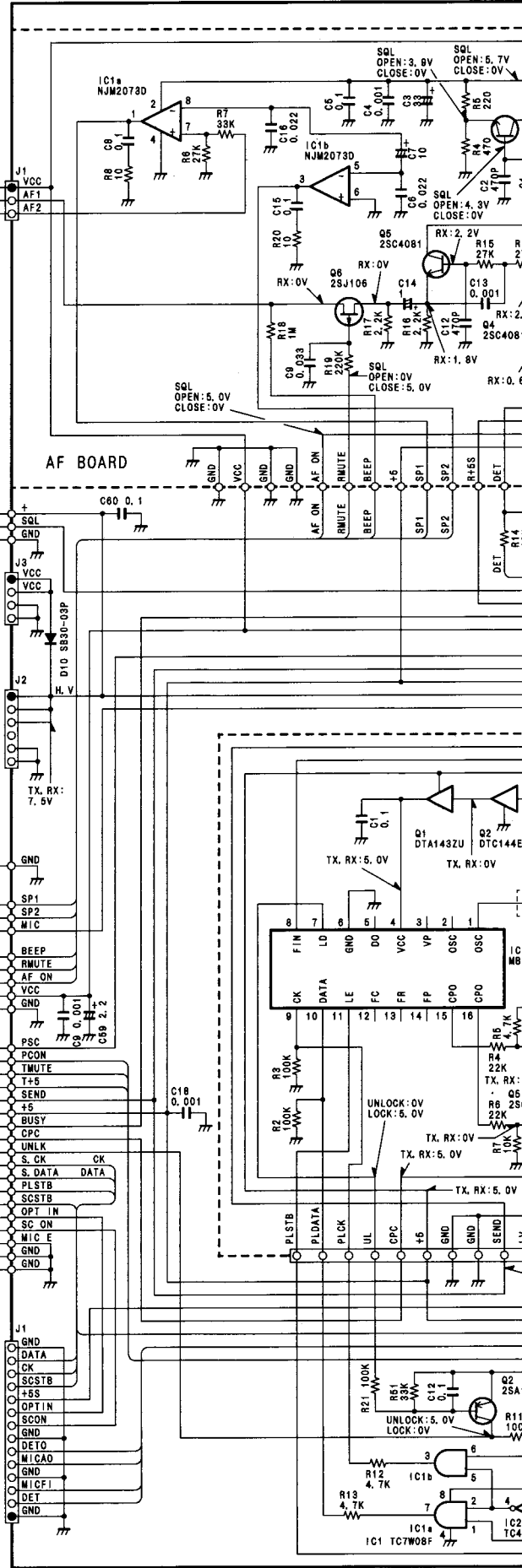
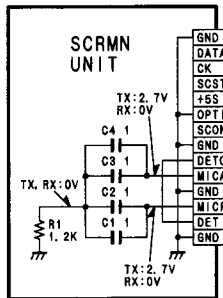
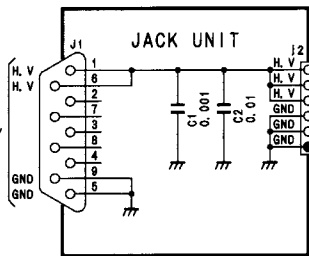
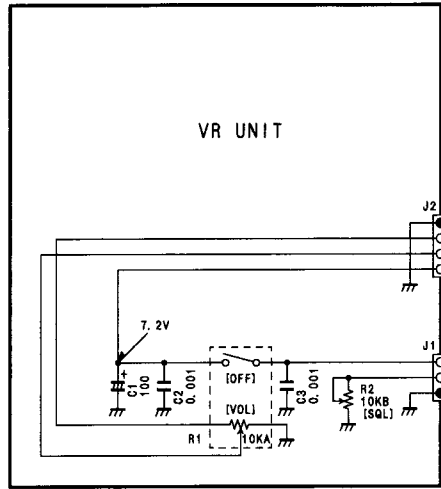
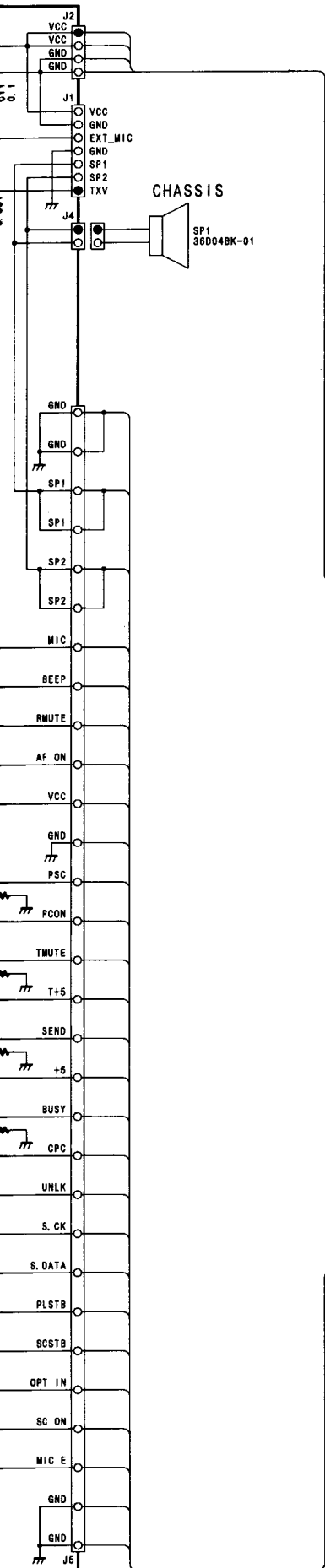

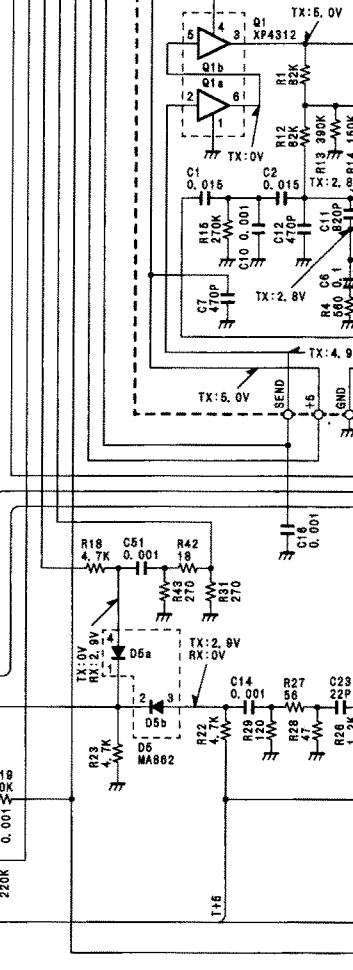
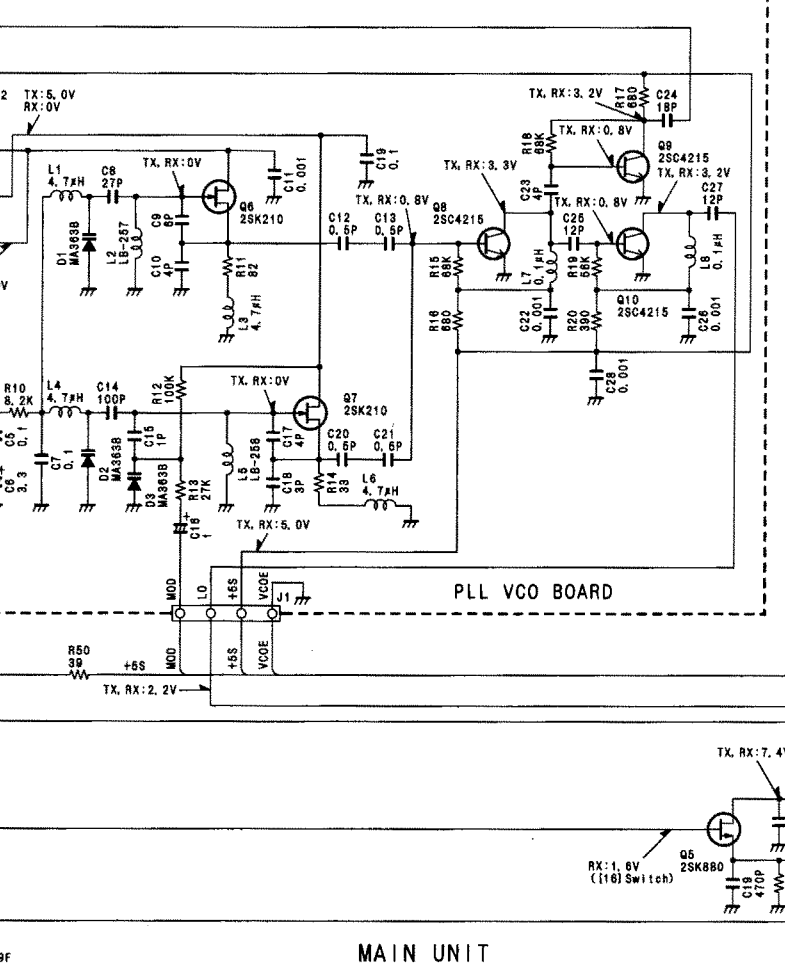
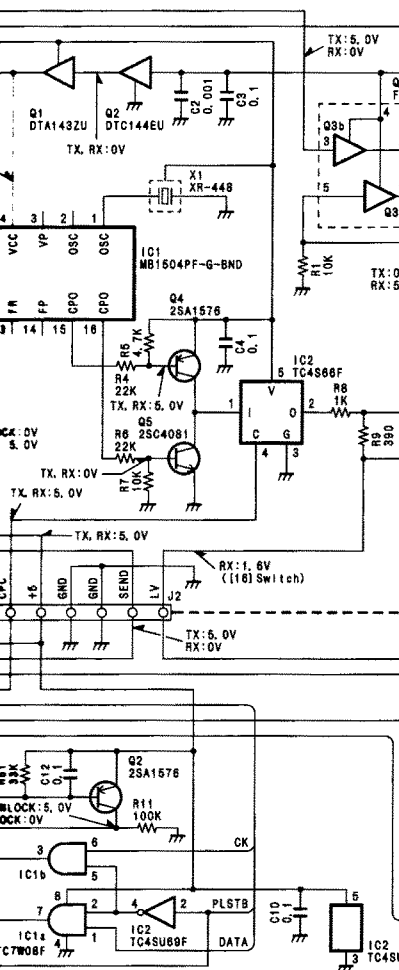
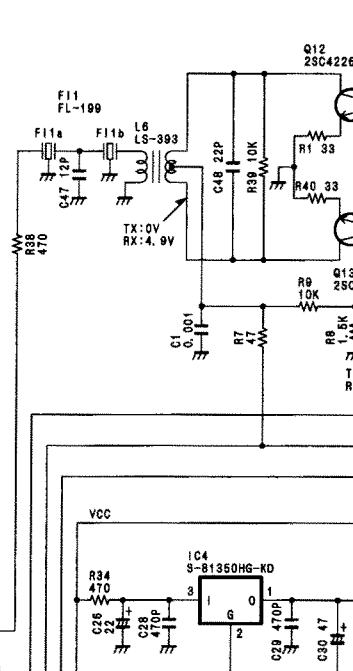
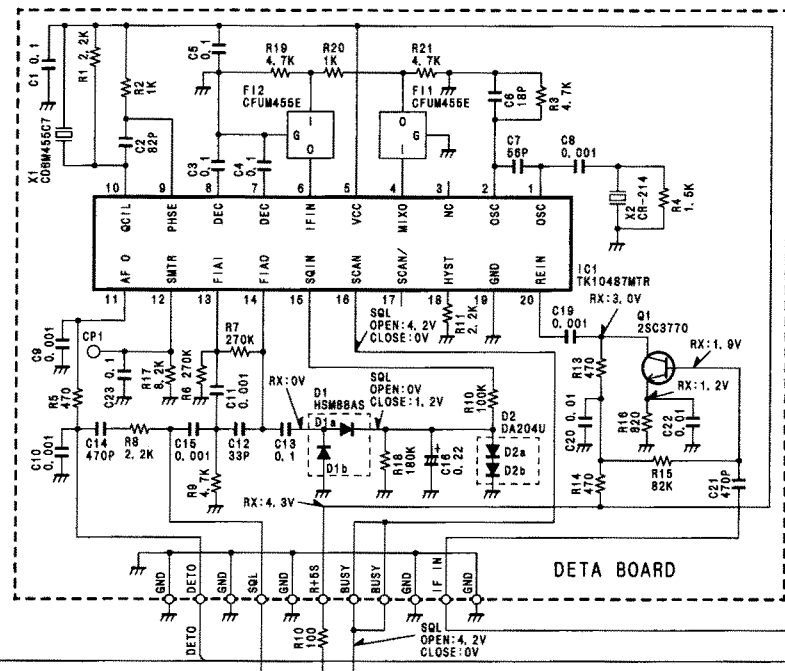
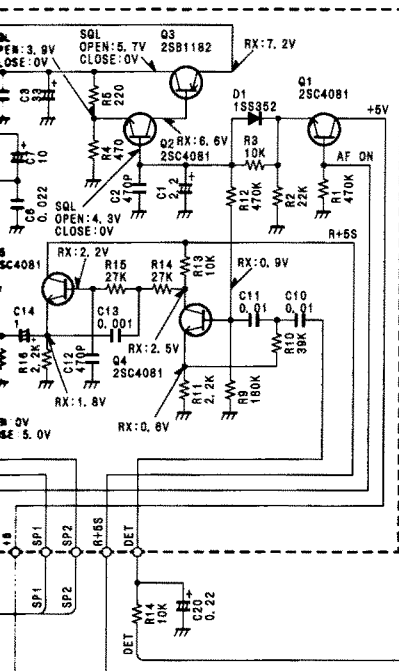

MAIN UNIT

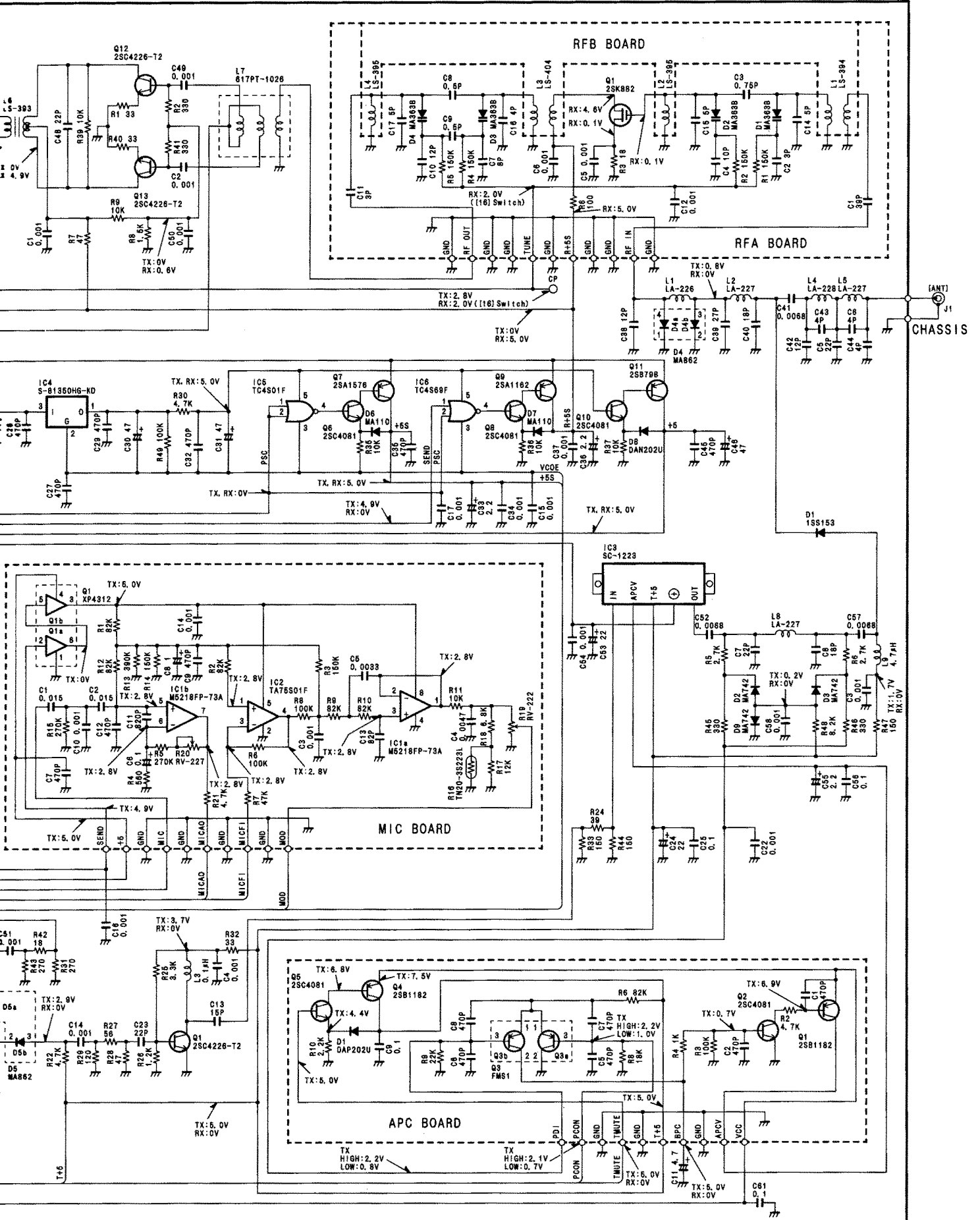

Icom Inc.

6-9-16, Kamihigashi, Hirano-ku, Osaka 547, Japan

Phone: 06 793 5302

Fax : 06 793 0013

Icom America Inc.

<Corporate Headquarters>

2380 116th Avenue N.E., Bellevue, WA 98004, U.S.A.

Phone : (206) 454-8155

Fax : (206) 454-1509

Telex : 152210 ICOM AMER BVUE

<Customer Service>

Phone : (206) 454-7619

<Regional Customer Service Center>

18102 Sky Park South, Suite 52-B, Irvine, CA 92714, U.S.A.

Phone : (714) 852-8026

Fax : (714) 852-8716

Icom Canada

A Division of Icom America Inc.

3071 #5 Road, Unit 9, Richmond, B.C., V6X 2T4, Canada

Phone : (604) 273-7400

Fax : (604) 273-1900

Icom (Europe) GmbH

Communication Equipment

Himmelgeister Str. 100, D-40225 Düsseldorf, Germany

Phone : 0211 346047

Fax : 0211 333639

Icom (Australia) Pty. Ltd.

A.C.N 006 092 575

7 Duke Street, Windsor, Victoria, 3181, Australia

Phone : 03 9529 7582

Fax : 03 9529 8485

Icom (UK) Ltd.

Unit 9, Sea St., Herne Bay, Kent, CT6 8LD, U.K.

Phone : 01227 741741

Fax : 01227 741742

Telex : 965179 ICOM G

Icom France S.a

Zac de la Plaine, Rue Brindejenc des Moulinais

BP 5804, 31505 Toulouse Cedex, France

Phone : 61. 36. 03. 03

Fax : 61. 36. 03. 00

Telex : 521515 ICOM FRA

Count on us!

Icom Inc.

6-9-16, Kamihigashi, Hirano-ku, Osaka 547, Japan

A-5226H-①

Printed in Japan

Copyright © 1993 by Icom Inc.